



n-fab.com

mfabinc f t

I-SHEET NUMBER: INST-00008
 PART NUMBER: D09-CCTX, D09-QCTX, D10-MCTX
 PRODUCT: GROWLER RUNNING BOARD
 APPLICATION: RAM 09-14 1500 10-14 2500-3500

HARDWARE DESCRIPTION		QTY.
HWKT-05482X		
HHCS-00568X	3/8"-16 X 1" GRADE 5 HEX CAP SCREW	6
CLIP-00647X	3/8"-16 X 1 3/4" BARREL NUT CLIP	6
FLTW-00663X	3/8" USS FLAT WASHER	6
FLHB-00797X	M8-1.25 X 25MM CLASS 8.8 HEX SERRATED FLANGE BOLT	6
FLNT-00696X	M8-1.25 CLASS 8 SERRATED FLANGE NUT	6
FLHB-00688X	3/8"-16 X 1" GRADE 5 HEX SERRATED FLANGE BOLT	12



PARTS INCLUDED	QTY
Running Boards	2
Rocker Panel mounting Brackets	6
Threaded clamp plates	6

GROWLER

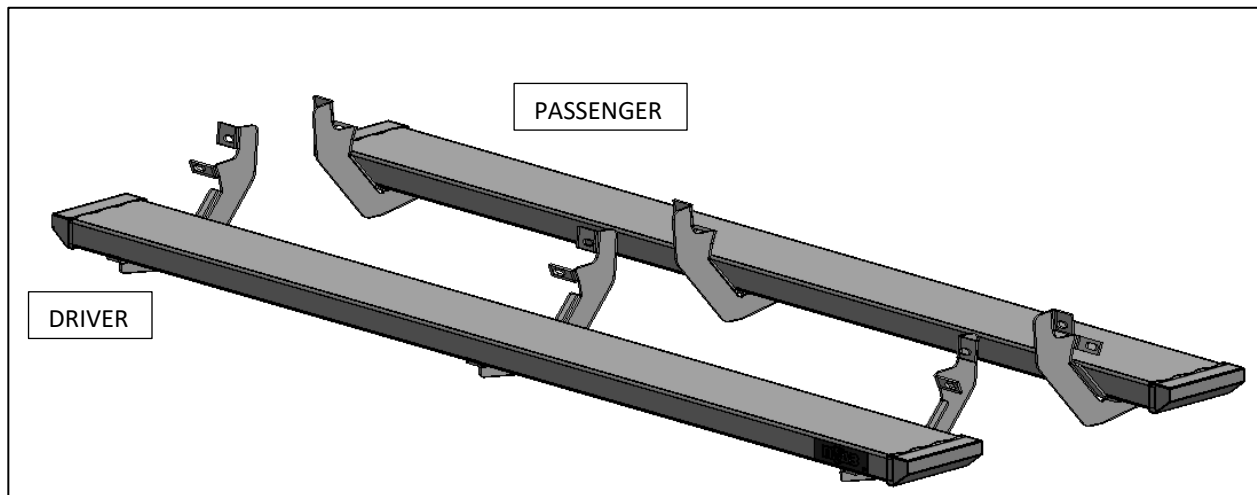

Step 1: Beginning with the driver side, remove any factory running boards or steps and discard.

Step 2: Next, locate the mounting holes underneath the body and remove the factory tape from the three locations.

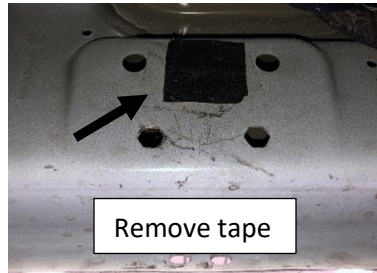

Step 3: Insert the supplied threaded U- clips in each mounting location.

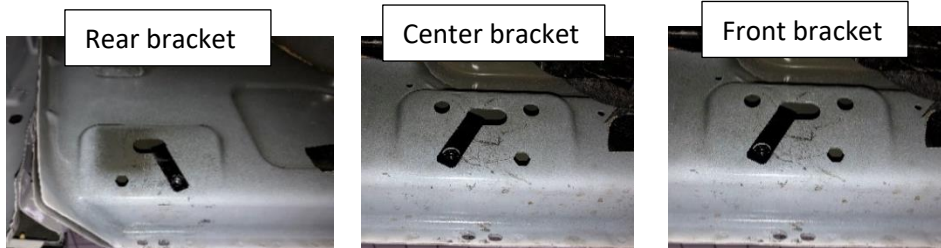

U-clip positioning. **NOTE:** U- Clip orientation will be the same for passenger

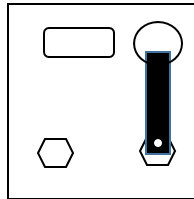

NOTE: If you have a 14-18 model you may have to drill a 1" round opening for the rear bracket location to add the clip. If so, go ahead and complete this step at his time.

Step 4: Some models may require drilling a hole in the pinch weld for the bottom mounting position. To do this, line up the mounting bracket with upper clip and make a mark on the pinch weld. With a 3/8" drill bit, drill a hole in the center. If this step is required, do so now.



Step 5: Install the (x3) rocker panel mounting brackets to the factory attachment points using the provided 3/8" x 1" hex bolts and 3/8" flat washers for the upper mount and the M8x25mm flanged bolt and M8 flanged nut for the pinch weld mount. Leave loose for now.

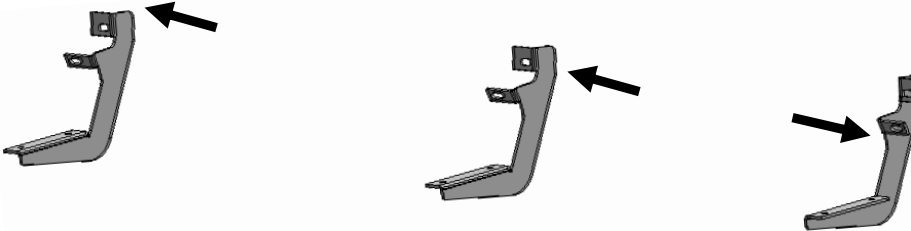

NOTE: Make sure the brackets are facing in the correct direction.

Step 6: Set running board along the top of both brackets and center along the cab.

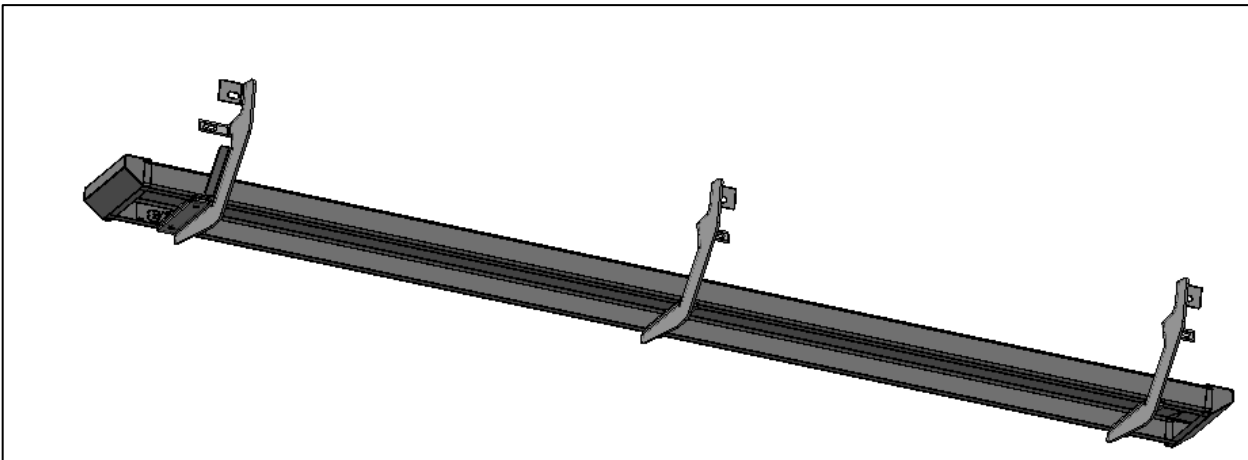

Step 7: Insert the supplied threaded brackets (x3) inside the running board lip over the top of each bracket.

Step 8: With the supplied 3/8" x 1" hex bolts, secure each mounting location and leave loose.

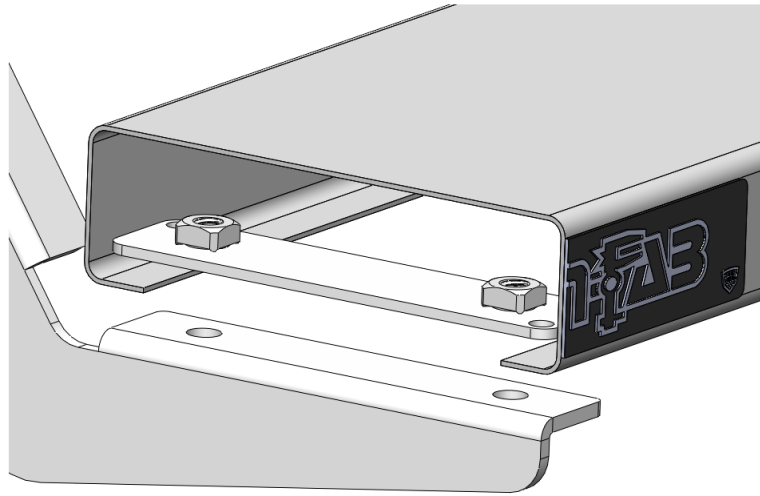

Step 9: After final adjustment, tighten all running board threaded mounts.

Step 10: Next, tighten the lower pinch weld attachment points (x3).

Step 11: Finish by tightening the upper mounts (x3).

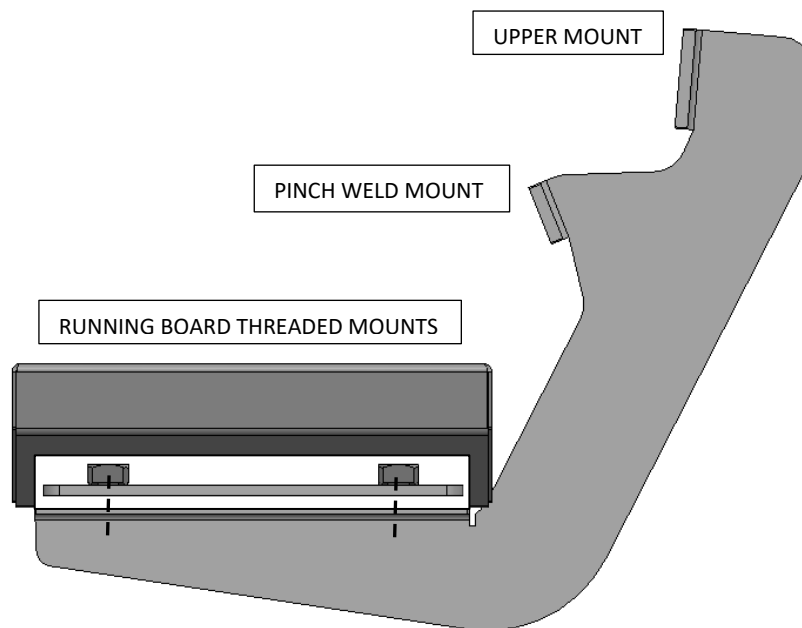

Step 12: Repeat steps 2-11 for passenger side.