



FITTING INSTRUCTIONS

Part Number: 3410100

Description: ARB "DAKAR" WINCH BAR TO SUIT TOYOTA LAND CRUISER
60 SERIES

WARNING

- ◆ When installed in accordance with these instructions, the front protection bar does not affect operation of the SRS airbag.
- ◆ This product must be installed exactly as per these instructions using only the hardware supplied.
- ◆ In the event of damage to any bull bar component, contact you're nearest authorised ARB stockist. Repairs or modifications to the impact absorption system must not be attempted.
- ◆ Do not use this product for any vehicle make or model, other than those specified by ARB.
- ◆ Do not remove labels from this bull bar.
- ◆ This product or its fixing must not be modified in any way.
- ◆ The installation of this product may require the use of specialized tools and/or techniques
- ◆ It is recommended that this product is only installed by trained personnel
- ◆ These instructions are correct as at the publication date. ARB Corporation Ltd. cannot be held responsible for the impact of any changes subsequently made by the vehicle manufacturer
- ◆ During installation, it is the duty of the installer to check correct operation/clearances of all components
- ◆ Work safely at all times
- ◆ Unless otherwise instructed, tighten fasteners to specified torque

www.arb.com.au

Corporate Head Office

42-44 Garden St
Kilsyth, Victoria
AUSTRALIA 3137



Tel: +61 (3) 9761 6622
Fax: +61 (3) 9761 6807

FITTING REQUIREMENTS

REQUIRED TOOLS FOR FITMENT OF PRODUCT:

Basic tool kit	Drill and 10mm drill bit
Test lamp	

HAVE AVAILABLE THESE SAFETY ITEMS WHEN FITTING PRODUCT:

Protective eyewear		Hearing protection	
--------------------	---	--------------------	---

NOTE: 'WARNING' notes in the fitting procedure relate to OHS situations, where to avoid a potentially hazardous situation it is suggested that protective safety gear be worn or a safe work procedure be employed. If these notes and warnings are not heeded, injury may result.

WHERE USED	PART No	QTY	DESCRIPTION
CHASSIS BRACKETS TO CHASSIS	3756862L	1	Chassis bracket assembly LHS
	3756862R	1	Chassis bracket assembly RHS
	5846279	4	Spacer chassis 32 x 14 x 24mm
	6151100	8	Bolt 1/2" x 1 1/2" hex head
	6151101	4	Bolt 1/2" x 2" hex head
	4581049	24	Washer flat 1/2"
	4581050	12	Washer spring 1/2"
	6151138	12	Nut 1/2" hex
BULL BAR TO CHASSIS BRACKETS	6151100	4	Bolt 1/2" x 1 1/2" hex head
	4581049	8	Washer flat 1/2"
	4581050	4	Washer spring 1/2"
	6151232	2	Bolt M10 x 1.5 x 30mm
	4581040	4	Washer flat M10
	4581048	2	Washer spring M10
NUMBER PLATE AND INDICATORS TO BAR	3751451	1	Bracket number plate
	6151017	4	Bolt M6 x 16mm
	6151046	4	Washer flat M6
	6151128	4	Nut flange M6
	3500080	1	Universal indicator kit
WINCH AND CONTROL BOX TO BAR	3756209	1	Bracket winch control box
	6151021	2	Bolt M8 x 20mm
	4581044	2	Washer flat M8
	6151132	2	Nut flange M8
	6151074	2	Bolt 3/8" x 1 3/4" hex head
	6151073	2	Bolt 3/8" x 1 1/2" hex head
	4581040	4	Washer flat M10
	4581048	4	Washer spring M10

FITTING PROCEDURE

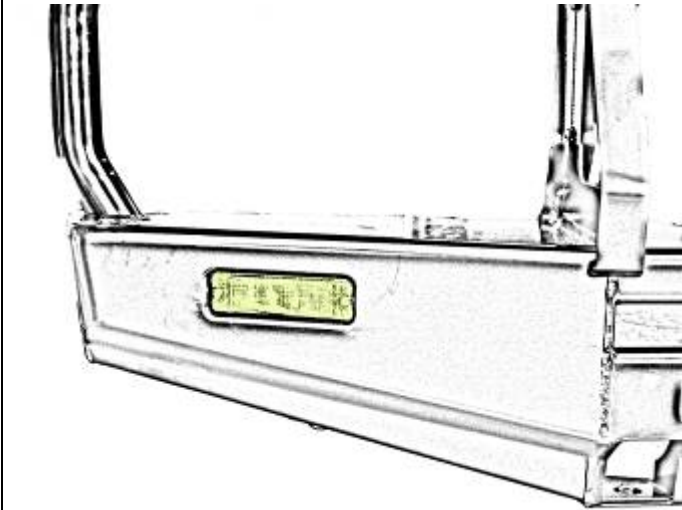

1. Place the bull bar on a suitable surface or stand and fit the indicators using the hardware provided in the indicator kit.

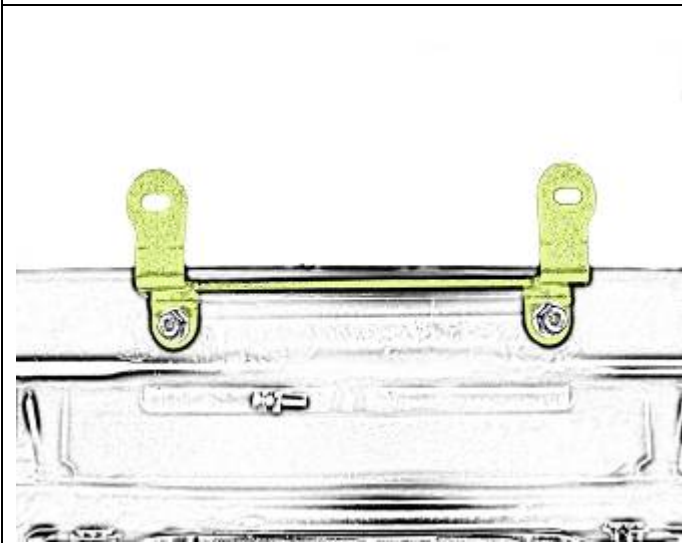

2. Fit the licence plate bracket to the bull bar using two M6 x 16mm bolts, M6 flat washers and M6 flange nuts.

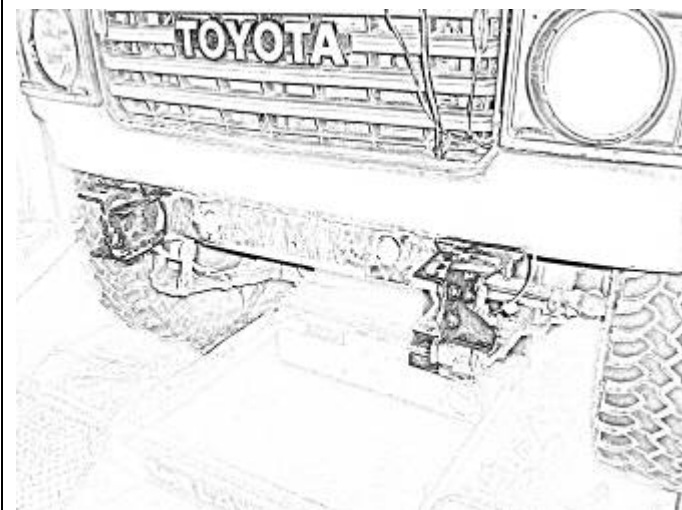

3. Remove the existing bumper bar or bull bar from the vehicle.

FITTING PROCEDURE

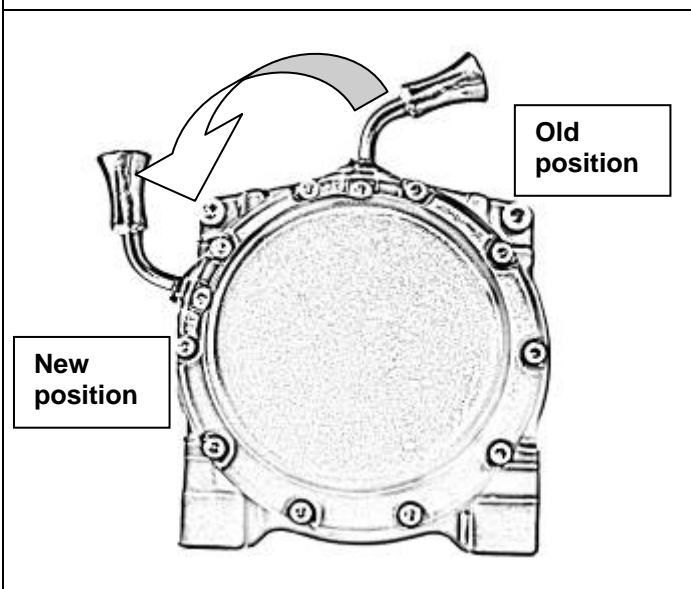

NOTE: IF NOT FITTING A WINCH PROCEED TO STEP 11

3. For low mount winches below 10000lb capacity, remove the ten cap screws from the gearbox and carefully lift and rotate the gearbox 72 degrees counter clockwise. (two hole spaces) Re-insert and tighten the cap screws.

Note: For high mount winches go to step 5.

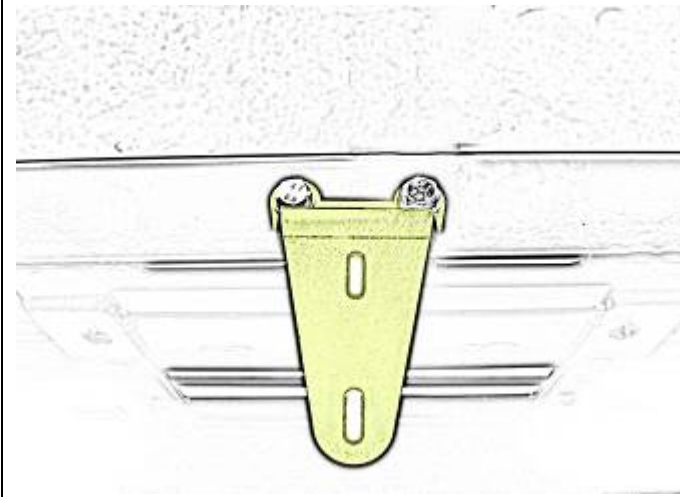

4. When fitting a low mount winch, fit the control box bracket to the bar. Fit using two M8 x 20mm bolts, M8 flat washers and M8 flange nuts.

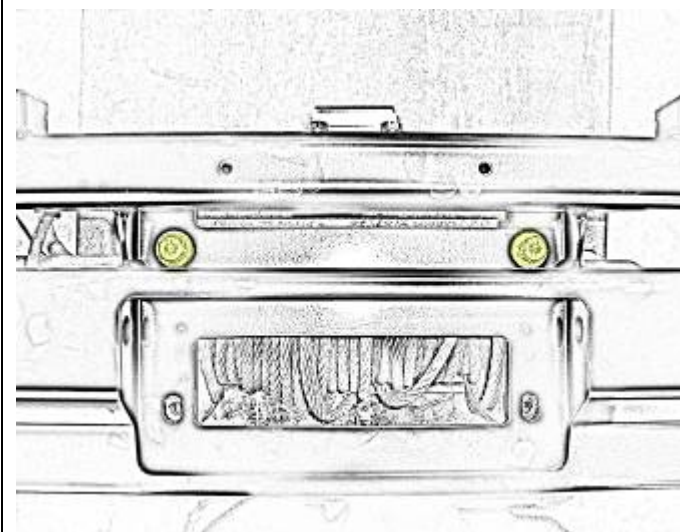

5. Lay the winch on a bench or stand with the legs facing upwards. With the help of an assistant, carefully place the bull bar over the top of the winch so that the holes line up with the winch mounting holes.
6. Fit the winch to the bar with two 3/8" x 1 1/2" bolts with M10 flat washers and M10 spring washers to the two top holes.

FITTING PROCEDURE

Drill the new hole 20mm below original



7. Using a 12mm drill bit, drill two new holes in the roller fairlead 20mm below the original holes.

Original

New hole

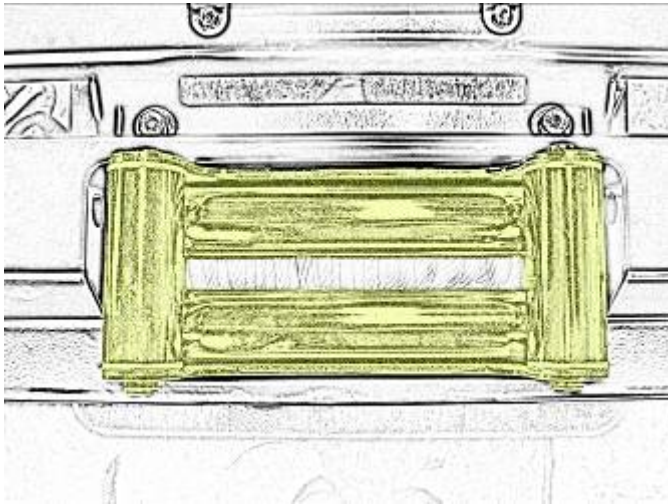

8. Fit the roller fairlead to the bar using two 3/8" x 1 3/4" bolts, M10 flat and spring washers. Tighten all winch bolts.

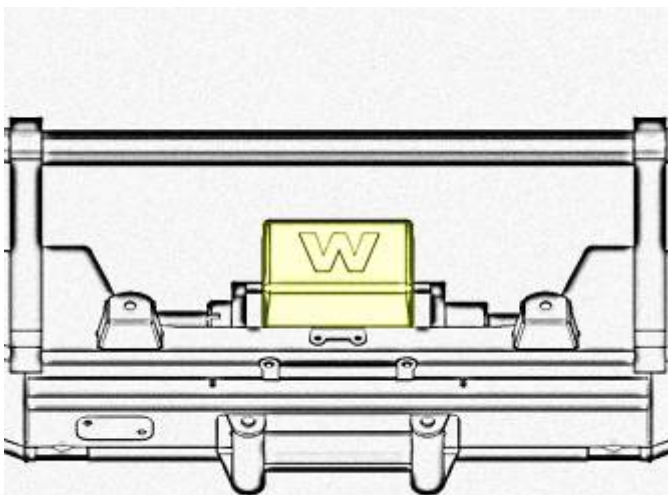

9. Fit the control box to the control box bracket using the nuts and washers that came with the winch kit.
10. Wire the control box to the winch according to the instructions provided with the winch.

FITTING PROCEDURE

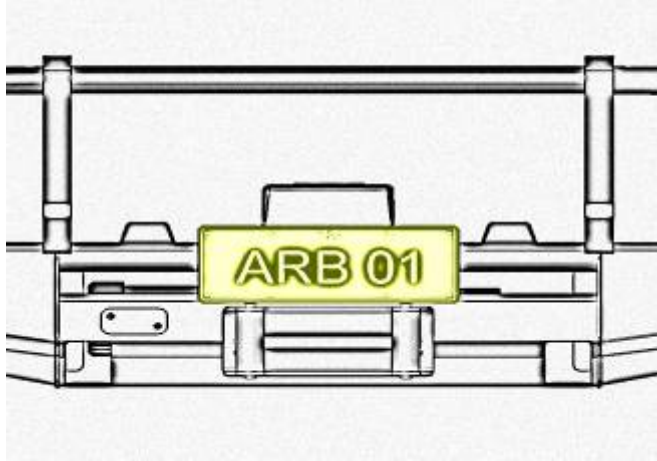

11. Fit the licence plate to the bull bar using two M6 x 16mm bolts, M6 flat washers and M6 flange nuts.

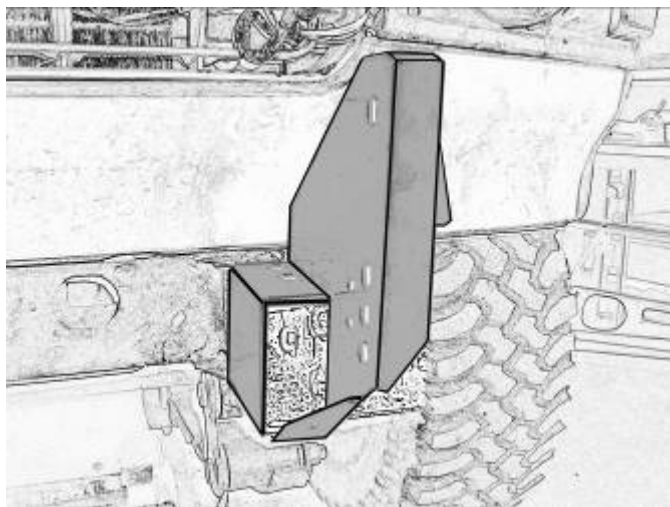

12. Fit the left and right hand bull bar mounting brackets to the appropriate chassis rails.

Note: Due to the age of the vehicles the use of a hammer may be necessary, if so use a piece wood against the part. Do not hit the part directly with the hammer.

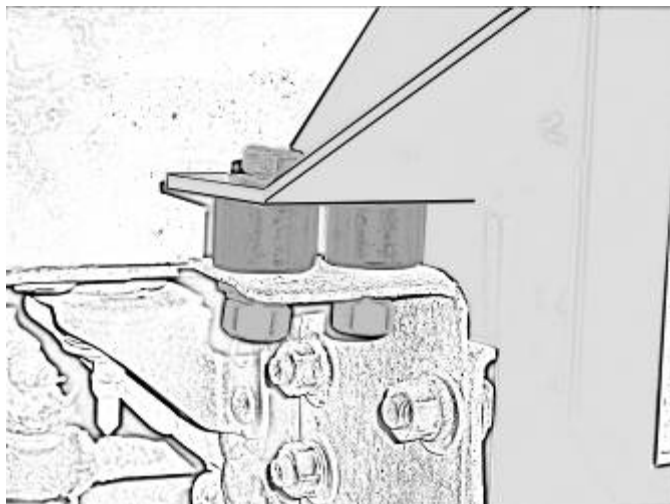

13. If necessary use the 25mm spacers provided in the fitting kit between the mounting bracket and the out riggers of the chassis. Fix in place with ½" x 2" bolts, ½" flat washers, ½" spring washers and ½" nuts. Do not tighten.

FITTING PROCEDURE

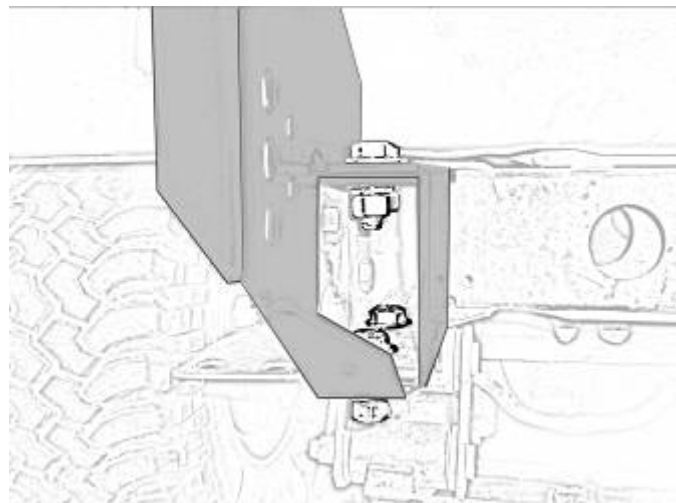

14. Fix the mounting bracket to the chassis using four $\frac{1}{2}$ " x $1 \frac{1}{2}$ " bolts, eight $\frac{1}{2}$ " flat washers, four $\frac{1}{2}$ " spring washers and four $\frac{1}{2}$ " nuts. When happy with the alignment of the brackets tighten all the bolts.

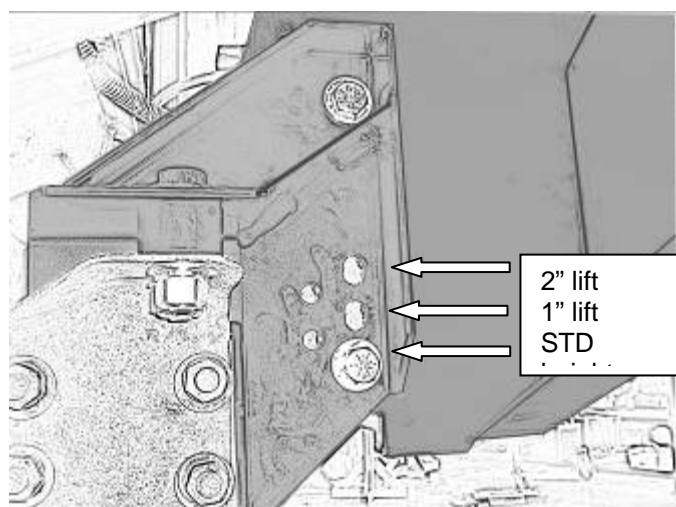

15. With the help of an assistant, lift the bar onto the mounting brackets. Align the holes in the bull bar with the holes in the mounting bracket to the desired height. (see diagram opposite)

16. Fix the bull bar in place using two $\frac{1}{2}$ " x $1 \frac{1}{2}$ " bolts, four $\frac{1}{2}$ " flat washers, two $\frac{1}{2}$ " spring washers and two $\frac{1}{2}$ " nuts for each side.



17. Using the hole in the mounting bracket as a guide, drill a 10mm hole through the bull bar upright for the pinning bolt.

18. Pin the bar using a M10 x 30mm bolt, two M10 flat washers, M10 spring washer and M10 nut. Tighten the bolt. Repeat for the other side.

Note: There are two holes provided for pinning depending on what height the bull bar has been set at.

19. With the bull bar fitted and all bolt tightened, wire the indicators and winch. (if fitted) Use a test lamp to find the correct wires for the indicators to tap into and use the scotch locks provided to join the wires together. Refer to the winch fitting instructions for correct wiring of the winch. Make sure all wiring is clear of hot, moving or sharp objects.

