



# OLD MAN EMU

## FITTING INSTRUCTIONS

# FK80

**Ford Superduty**  
**2008-2010 F250/350**  
**Radius Arm Drop Bracket**

### HAND TOOLS REQUIRED

Ring / Open end Spanner set (Metric)  
Socket Set (Metric)  
Inc. 30mm and 24mm  
Torque Wrench

### WORKSHOP TOOLS REQUIRED

### OPTIONAL HAND TOOLS

Pry Bar

# KIT CONTENTS

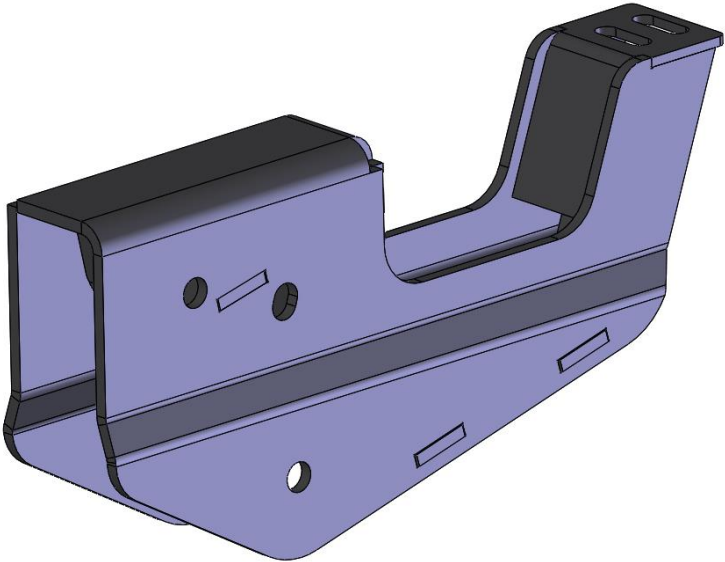
PART NO.	QTY	Description	Picture
3759353	2	Radius Arm Drop Bracket	
6151672	4	Bolt M18 x 130mm	
6151673	4	Nut M18 Nyloc	
4584357	8	Flat Washer 3/4	
6151637	4	Bolt M10 x 45mm	
6151359	4	Nut M10 Nyloc	
4581048	4	Washer M10 Spring	
4581040	4	Washer M10 Flat	

## Fitment Notes

- This kit should be fitted after raised Old Man Emu suspension has been installed.
- Fit only one side at a time, to avoid serious injury

## Fitting Procedure

1. Disconnect front lower shock mount, this enables access to other bolts.

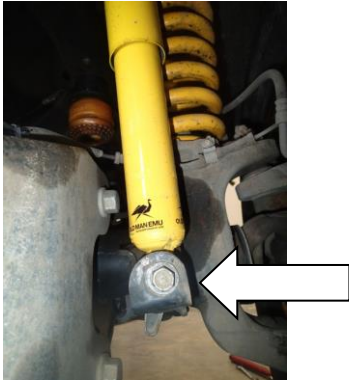

2. Where radius arm mounts to axle, loosen but **do not** remove the two M18 bolts.

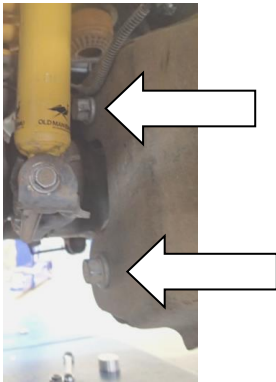

3. Disconnect the ABS plug and clip that runs along the top of the radius arm.

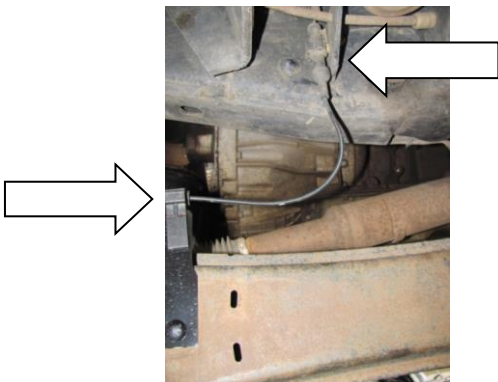

4. **CAUTION:** The radius arms keep the axle in place underneath the vehicle, at all times at least one of two radius arms must be fully connected. Work only on one side at a time from this step on, failure to do so may event in serious injury.

5. Where radius arm mounts to vehicle chassis, loosen and remove M18 fastener to disconnect radius arm, you may need to use heat to break down the chemical locking compound.

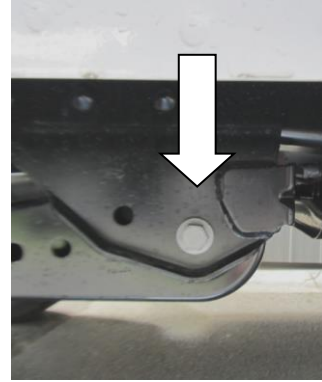

6. Remove top M18 bolt of radius arm on axle end pivot radius arm to the ground.  
Note. If also fitting OME FK71, fit brackets 3759368 at this point.



7. Insert OME radius arm drop bracket, insert both newly supplied M18 x 130mm bolts (6151672) with flat washers and nyloc nut loosely.

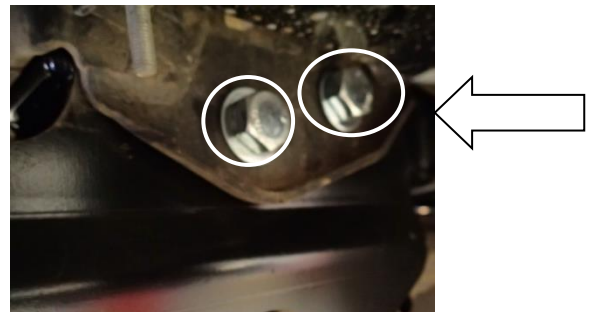

8. Insert M10 x 45mm to fix rear end of OME drop bracket to chassis and Tighten. Torque to 50 Nm. (37 lbf.ft)

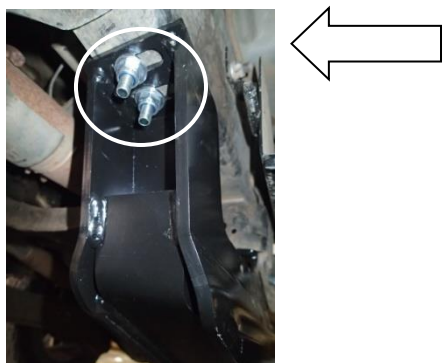

9. Tighten supplied 2 x M18 Bolts and Nyloc nuts on radius arm bracket. Torque to 350Nm (260 lbf.ft)

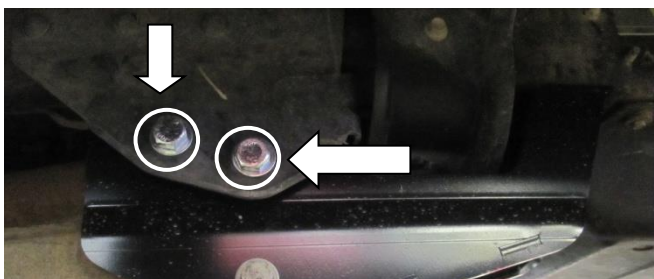

10. Insert top M18 bolt of radius arm on axle end loosely, then lever radius arm into new drop bracket, using original M18 bolt to fix, you may need to push/pull the wheel to get the holes to align the fastener with the mount hole.

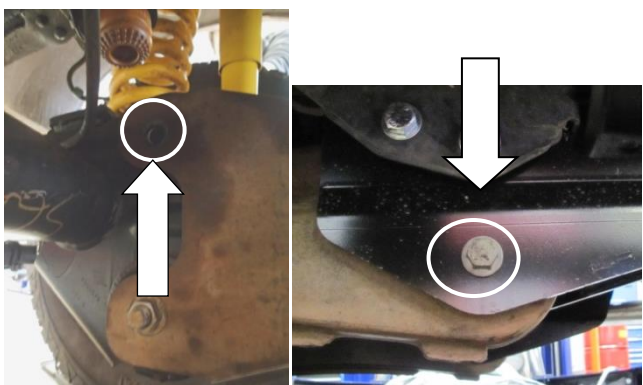

11. Torque 2 x M18 Bolts on the axle end of the radius arm and 1 x M18 bolt on the radius arm fixed end to 350 Nm (260 lbf.ft)

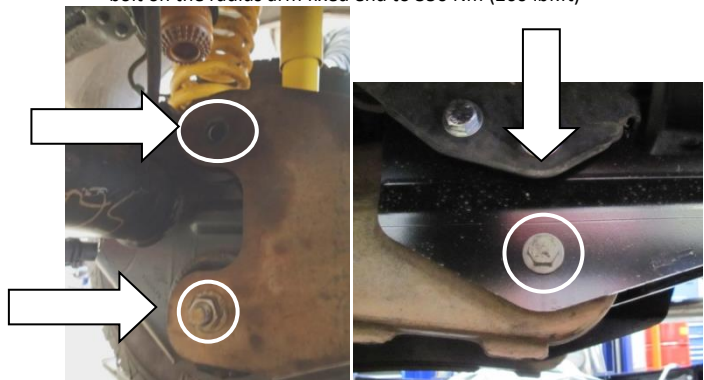

12. Reconnect ABS plug and clip.

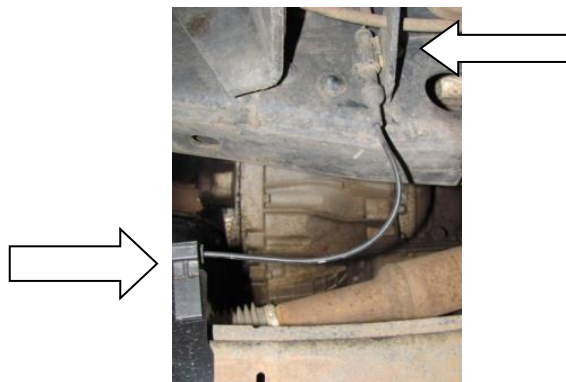

13. Repeat above steps for other side.

14. Tighten lower shock mounts on both sides. Torque to 100 Nm.

