

FITTING INSTRUCTIONS

BP5190005L & BP5190005R FORD RANGER PX ON FRONT MAZDA BT50 ON FRONT

WARNING

- ◆ This product must be installed exactly as per these instructions using only the hardware supplied.
- ◆ In the event of damage to any suspension component, contact your nearest authorised ARB stockist. Repairs or modifications to the suspension system components must not be attempted.
- ◆ Do not use this product for any vehicle make or model, other than those specified by ARB.
- ◆ Do not remove labels from suspension components.
- ◆ This product or its fixing must not be modified in any way.
- ◆ The installation of this product may require the use of specialized tools and/or techniques
- ◆ It is recommended that this product is only installed by trained personnel
- ◆ These instructions are correct as at the publication date. ARB Corporation Ltd. cannot be held responsible for the impact of any changes subsequently made by the vehicle manufacturer
- ◆ During installation, it is the duty of the installer to check correct operation/clearances of all components
- ◆ Work safely at all times

Note: These fitting instructions should be read in conjunction with the vehicle workshop manual.

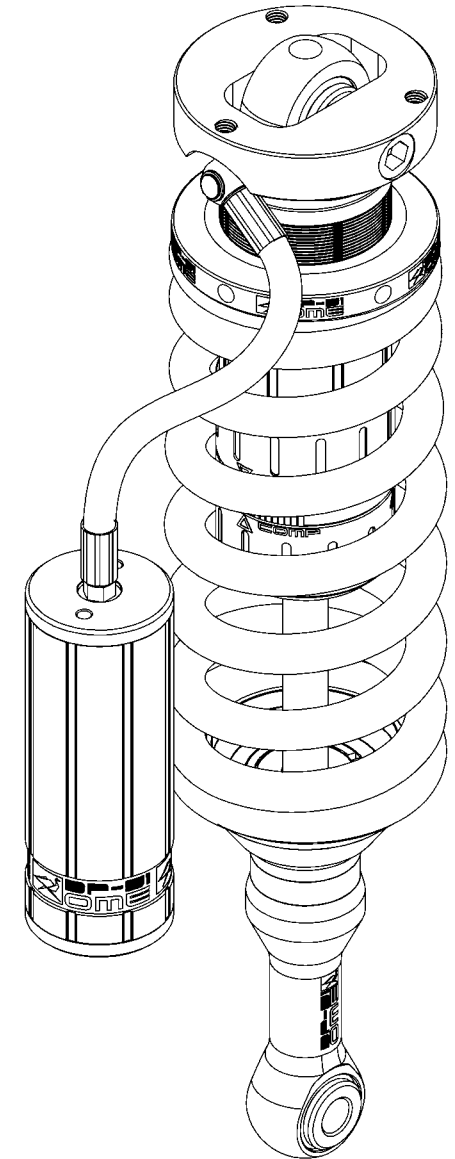

FITTING KIT CONTENTS – VM80010011

Item	Description	Qty.	Part No.
1	RESERVOIR CLAMP	2	VE10010003
2	PX RANGER RESI BRACKET FRONT RIGHT (SHOWN)	1	VE10020014R
3	PX RANGER RESI BRACKET FRONT LEFT	1	VE10020014L
4	ADJUSTER TOOL	1	VC10010071
5	PX RANGER FASTENER KIT FRONT	1	VM60010006
4.1	M10 X 1.5 X 30MM BOLT	4	6151555
4.2	M10 X 1.5 X 25MM BOLT	2	VD60030006
4.3	M6 X 30MM BOLT	6	6151228
4.4	M6 SPRING WASHER	6	4581287
4.5	M6 CAGED NUT BRACKET	6	VE10040003
5.6	M6 CAGED NUT	6	6151315
4.7	M6 X 16MM BOLT	4	VD60030003
4.8	M6 FLAT WASHER	10	VE70020005
4.9	M6 NYLOCK NUT	4	VD60010003

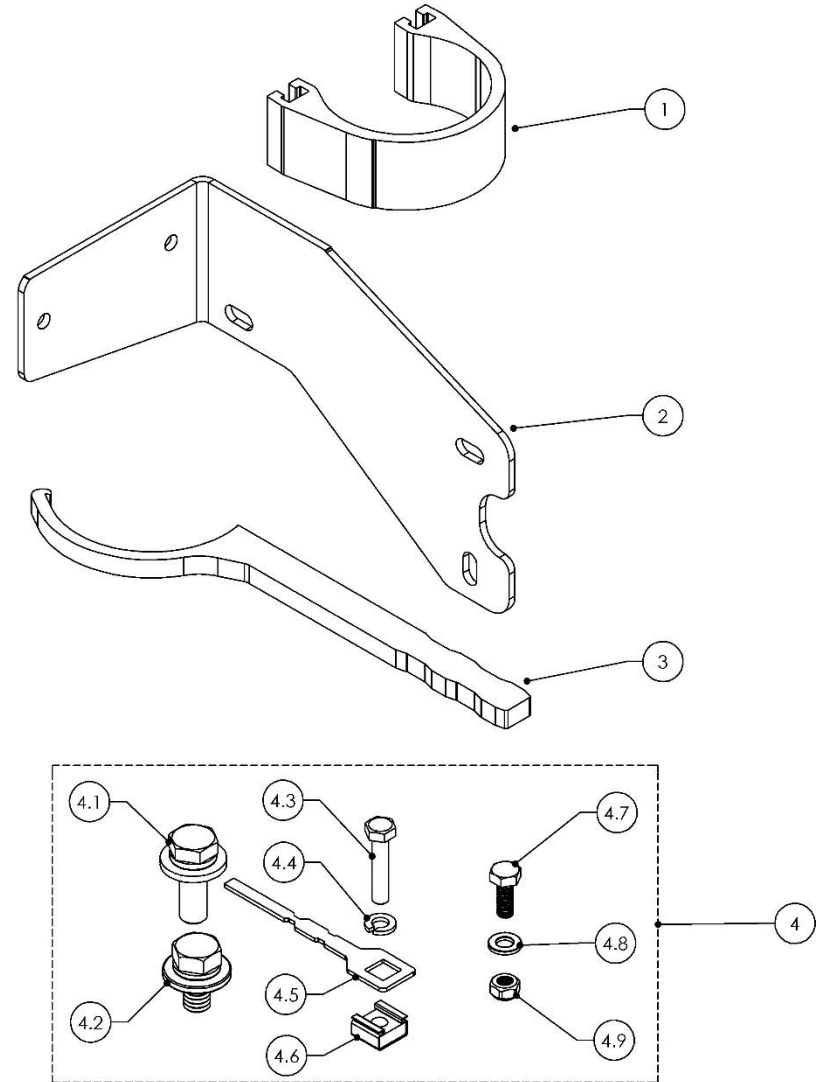

DAMPER PREPARATION

Before fitment the spring preload may need to be adjusted to suit your front accessory fitment and desired ride height.

Use workshop tool kit VM80020001 to aid spring adjustment.

The preload is set at the factory to 25mm as shown by the diagram. This aims to achieve 30-40mm increase in ride height over OE when a Bull Bar and winch are fitted.

It is required to set the preload before the strut assembly is fitted to the vehicle. Use a spring compressor to compress the spring, loosen the pinch bolt on the preload ring and adjust to the desired setting. Tighten the pinch bolt and remove the strut assembly from the spring compressor.

As a guide, set the preload as specified below to achieve 30-40mm increase in ride height.

<u>Front accessories</u>	<u>Preload</u>
Bar & winch	25 mm
Bar only	20 mm
No accessories	15 mm

Spring preload must only be adjusted when a spring compressor is used to take load off the preload ring.

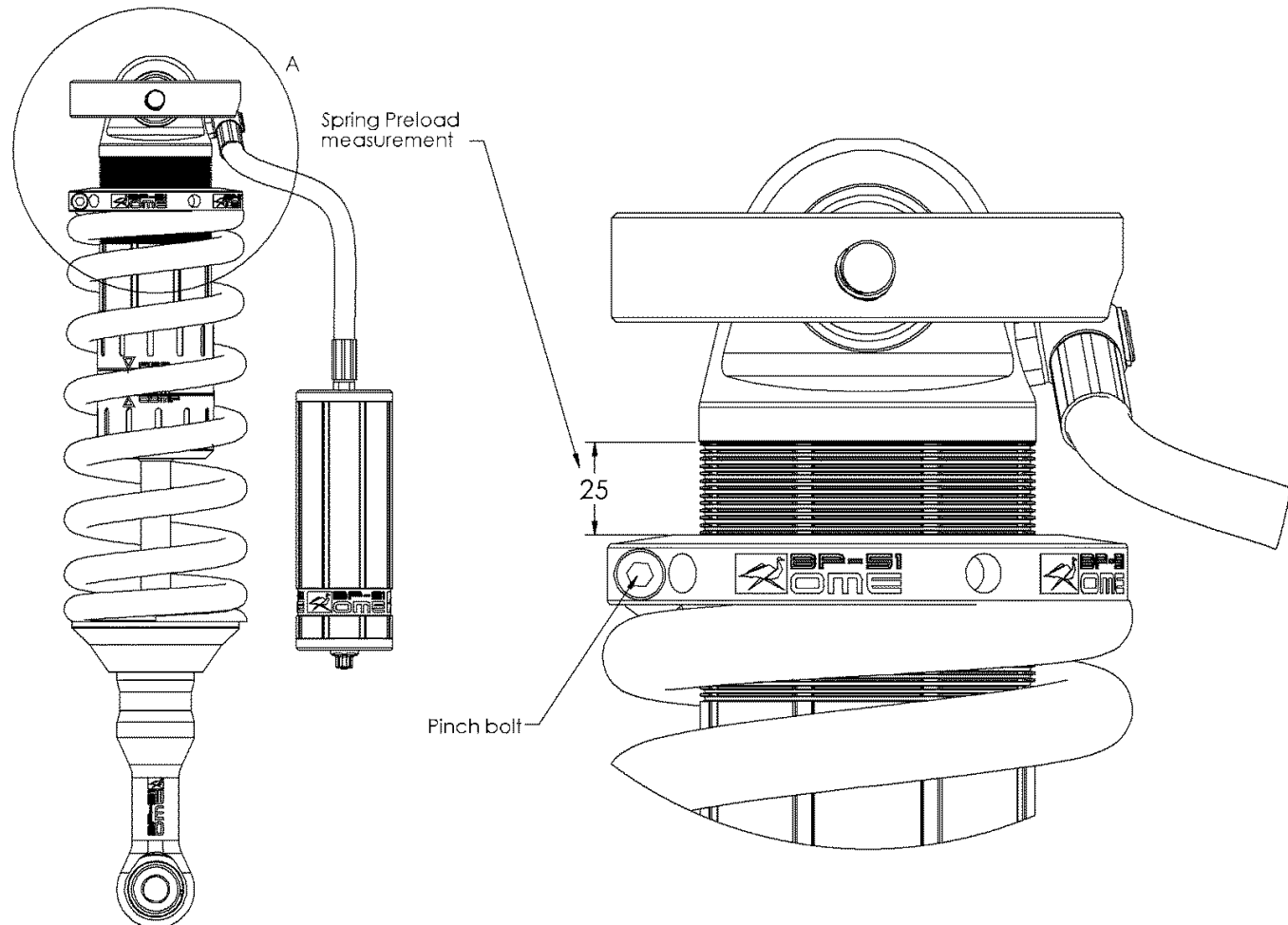

DAMPER MOUNTING SEQUENCE

Remove old dampers from vehicle.

Support the Lower Control Arm with a jack stand or similar (1).

For LH and RH detach the ball joint from steering arm (2). Detach ESC line as shown (3). Remove sway bar link (4) and repeat for both sides. Push sway bar out of operating area. Finally remove brake line bracket from the upright (5).

To provide access for removing and inserting the strut assemblies, detach the upright from the upper control arm (UCA) and take care to prevent the drive shaft from dropping out, when the strut has been removed, reattach the UCA and upright. Secure with the associated nut, finger tight (6).

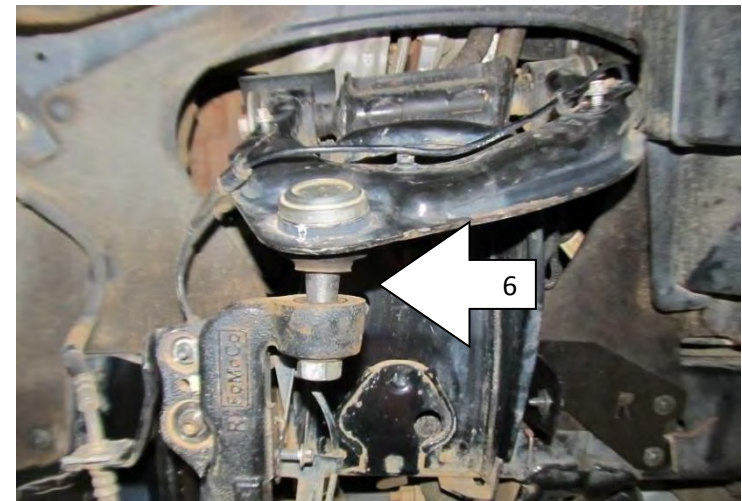
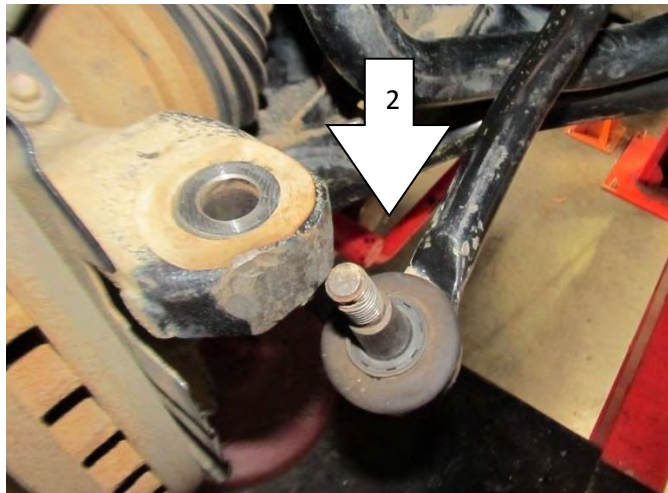
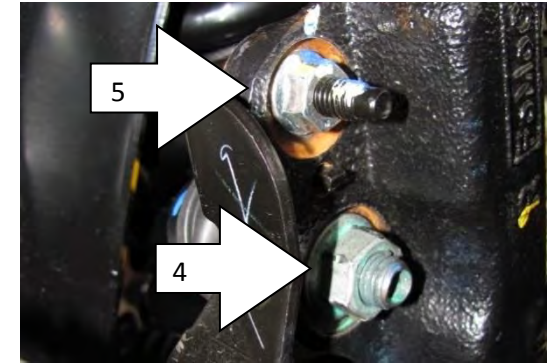
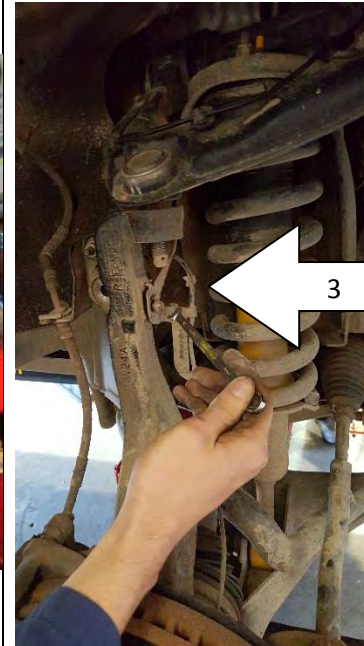

DAMPER MOUNTING SEQUENCE

Left and Right differ by how the reservoir hose exits the damper. L and R should be etched on the damper part number. When mounted in the vehicle the hose and reservoir should be towards the front of the vehicle.

Fit the damper and secure the top mount with bolts and washers finger tight. (1)

Secure bottom mount using original bolt and nut. (2)

Fasten top three bolts and bottom bolt securely and torque as shown below.

Fastener	Torque N.m (ft.lb)
Sway bar link to upright	70 (52)
Steering tie rod end to upright	88 (65)
Strut top hat	44 (32)
Strut to lower control arm	230 (170)

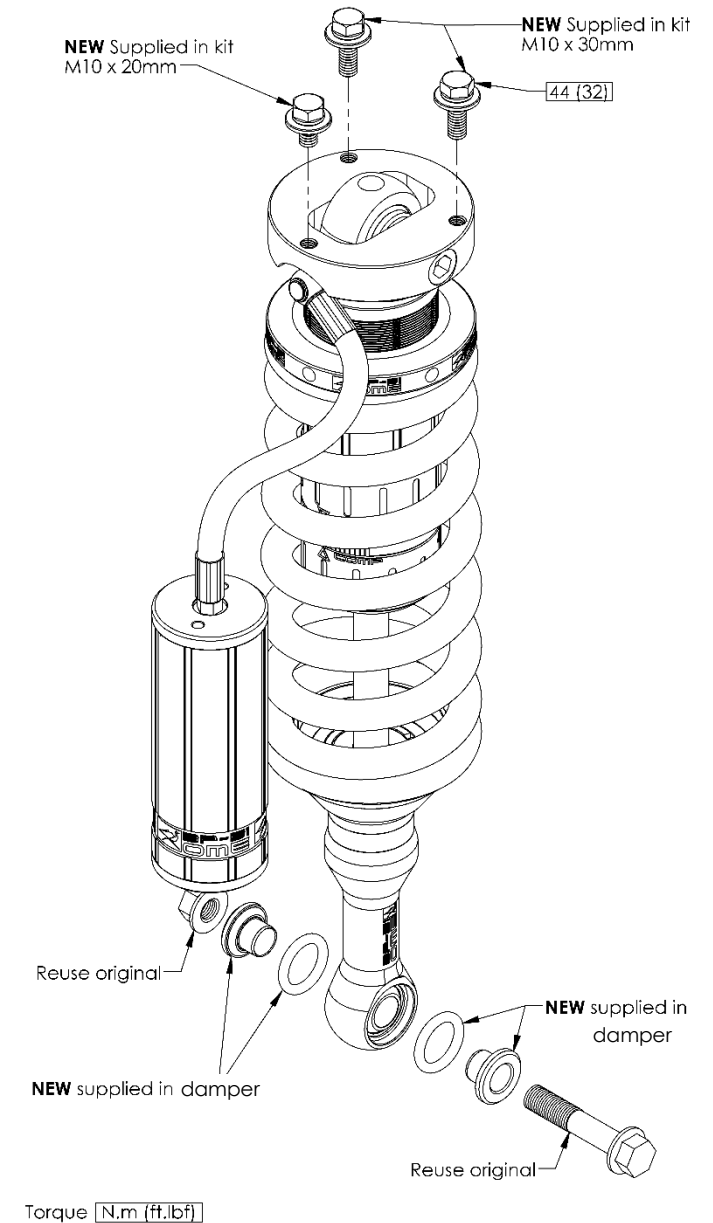
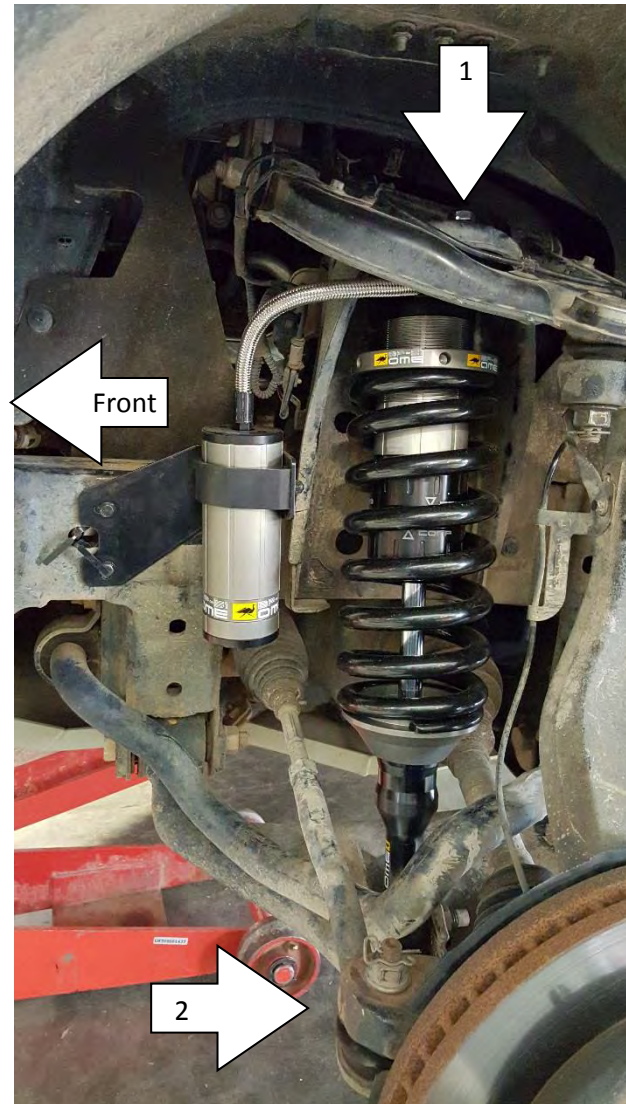

RESERVOIR MOUNTING SEQUENCE

Locate the hole positions on the chassis rail and remove the two screws on the mud flap (1).

Fit two M6x16mm bolts to mounting plate finger tight with nyloc nut and flat washer (2).

Fit the reservoir mounting plate to the **outside of the chassis rail**. Insert the Secure with new M6 x 30mm bolt, spring and flat washer. Fold mud flap over chassis rail away from the reservoir.

Fit the mounting saddle to the reservoir by sliding the heads of the bolts through the slots in the mounting saddle (4). Centralise the saddle on the plate and adjust the position of the reservoir as shown (5). Fasten M6 nuts.

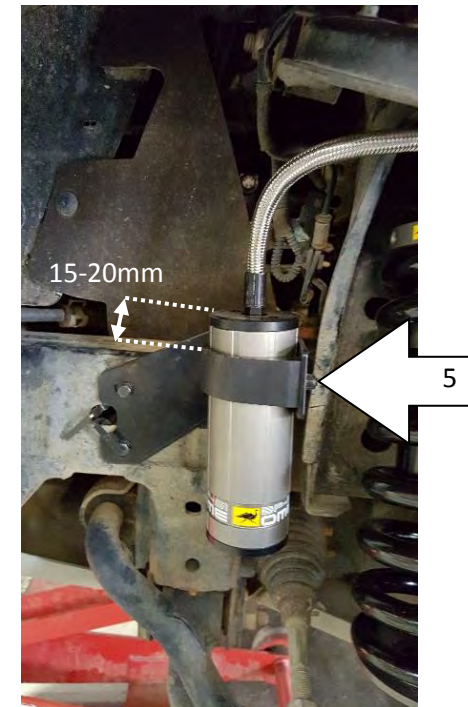
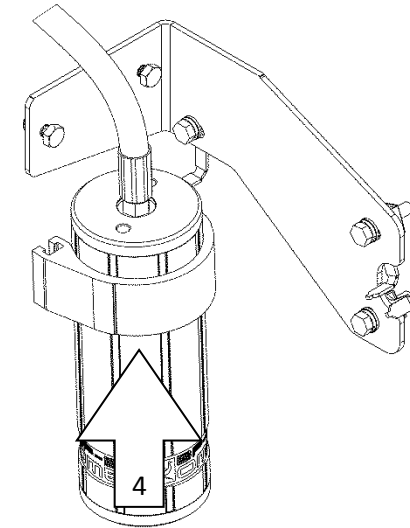
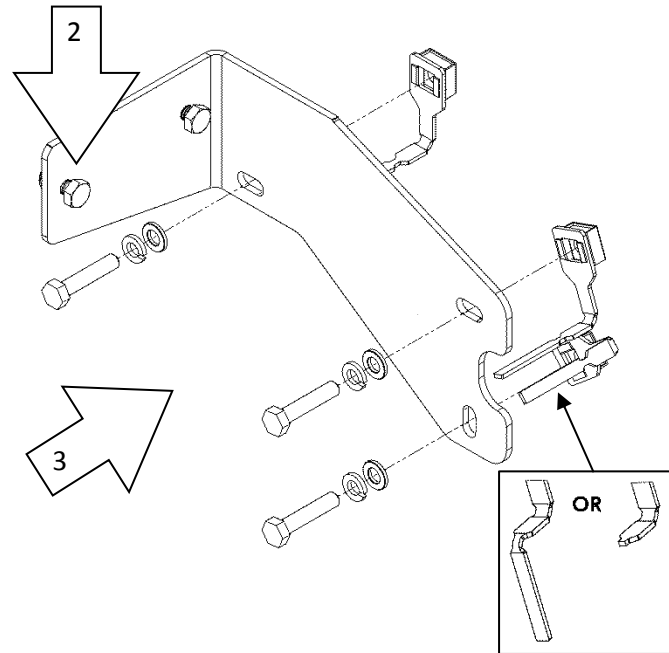
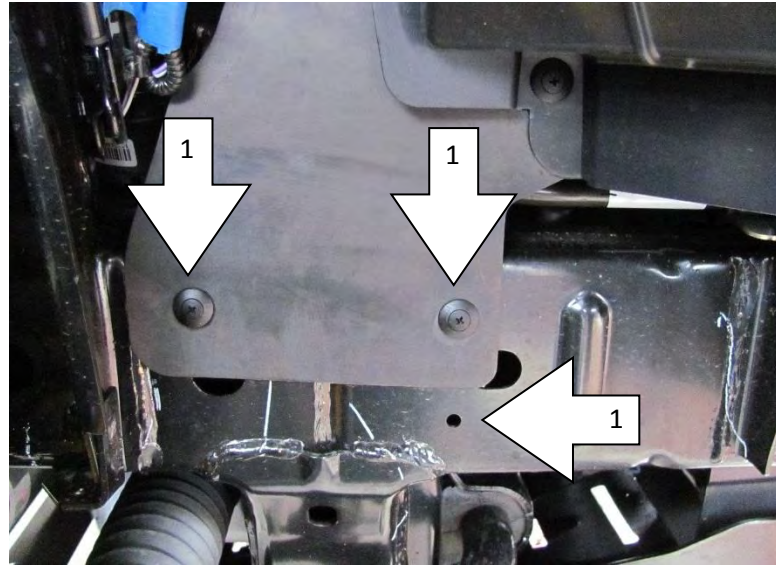

DAMPING ADJUSTMENT

These dampers have been set in the factory to be used for a vehicle with Bull Bar and Winch fitted.

If your accessory fitment differs, use the table below as a guide for recommended Compression and Rebound adjuster settings.

Refer to the Owner's Manual for more information.

Front Accessories	Compression	Rebound
Factory setting	3	6
Bar & winch	4-8	6-10
Bar only	2-6	5-9
No accessories	0-4	4-8

SPECIFICATIONS

- 1 Extended Length 505mm
- 2 Compressed Length 339 mm

SPARE PARTS

Refer to Service And Part manual, section: **BP-51 S&P 3.1-BP5190005L&R.**

