



FITTING INSTRUCTIONS

Part Number: **3580020**
Product **JACK MOUNTING BRACKET**
Description:
Suited to **FORD BRONCO**
vehicle/s:

WARNING

ALSO, NOTE THE FOLLOWING:

- ◆ This product must be installed exactly as per these instructions using only the hardware supplied.
- ◆ In the event of damage to any mount component, contact your nearest authorised ARB stockist.
- ◆ Do not use this product for any vehicle make or model, other than those specified by ARB.
- ◆ This product or its fixing must not be modified in any way.
- ◆ The installation of this product may require the use of specialized tools and/or techniques.
- ◆ It is recommended that this product is only installed by trained personnel.
- ◆ These instructions are correct as at the publication date. ARB Corporation Ltd. cannot be held responsible for the impact of any changes subsequently made by the vehicle manufacturer.
- ◆ During installation, it is the duty of the installer to check correct operation/clearances of all components.
- ◆ Work safely at all times.
- ◆ Unless otherwise instructed, tighten fasteners to specified torque.

ARB 4x4 ACCESSORIES

Corporate Head Office

42-44 Garden St
Kilsyth, Victoria
AUSTRALIA 3137

Tel: +61 (3) 9761 6622
Fax: +61 (3) 9761 6807

Australian enquiries
North & South American enquiries
Other international enquiries

sales@arb.com.au
sales@arbusa.com
exports@arb.com.au

www.arb.com.au

GENERAL CARE AND MAINTENANCE

By choosing an ARB Accessory, you have bought a product that is one of the most sought after 4WD products in the world. Your Accessory is properly engineered, it's reliable and is a quality accessory that represents excellent value. To keep your Accessory in original condition it is important to care and maintain it following these recommendations:



- As part of any Pre Trip Preparation, or on an annual basis, it is recommended that a thorough visual inspection of the vehicle's accessories is carried out, making sure that all bolts and other components are torqued to the correct specification. Also check that all wiring sheaths, connectors, and fittings are free of damage. Replace any components as necessary. This service can be performed by your local authorized ARB Stockist.

FITTING REQUIREMENTS

REQUIRED TOOLS FOR FITMENT OF PRODUCT:

BASIC TOOL KIT	TORX KEYS
ALLEN KEYS	Loctite 243

HAVE AVAILABLE THESE SAFETY ITEMS WHEN FITTING PRODUCT:

Protective eyewear		Hearing protection	
--------------------	---	--------------------	---

NOTE: 'WARNING' notes in the fitting procedure relate to OHS situations, where to avoid a potentially hazardous situation it is suggested that protective safety gear be worn or a safe work procedure be employed. If these notes and warnings are not heeded, injury may result.

FASTENER TORQUE SETTINGS:

SIZE	Torque Nm	Torque lbft
M6	9Nm	7lbft
M8	22Nm	16lbft
M10	44Nm	32lbft

PARTS LISTING

APPLICATION.	PART NO.	QTY	DESCRIPTION
FIT JACK DOOR MOUNT	4655161	1	JACK DOOR MNT WELDMENT
	3195505	2	NUT STICK M6 X 165MM
	3195506	1	TOP NUT STICK
	3195507	1	BOTTOM NUT STICK
	6151300	8	NUT CAGED M6 2.6-3.5 956-C
	6151207	8	BOLT HXHD M6x1.0x25 PC8.8 TZP480
	4584295	8	WASHER FLAT M6x12 BZP
	6151526	6	NUT CAGED M6 1.8-2.7 BZP480
FIT DRESS PLATE	6523550	1	LOGO COVER
	6151443	6	SCREW BHD M6x20 BZP
FIT PIVOT SHAFT MOUNTING	4681760	2	PIVOT SHAFT MNT
	4765021	2	MACHINED SHAFT M10
	4584295	20	WASHER FLAT M6x12 BZP
	6151443	8	SCREW BHD M6x20 BZP
	6151223	8	NUT HEX NYLOC M6x1.0 ZNB480
	6151711	2	SCREW BHD M6x25 TX BTZP480
FIT JACK CLAMPS	6582515	1	FORGED JACK MNT CLAMP SHORT
	6582517	1	FORGED JACK MNT CLAMP LONG
	6152099	2	SCREW SCHD M6x1x75 ZNB480
	4584295	4	WASHER FLAT M6x16x1.2 HV300
	6151223	2	NUT HEX NYLOC M6x1.0 ZNB480
	6152109	2	LANYARD
	4584430	4	WASHER FLAT 6.3x12.5x3 NYLON BLACK
FIT RUBBER AND KNOBS	6191170	2	JACK CLAMP RUBBER
	6191171	1	JACK CLAMP HANDLE RUBBER
	6260009	2	RUBBER SPACER BUSH
	6151753	2	SCREW BHD M10x1.5x25
	6151842	2	NUT HEX M10x1.5 ZNB480
	6152055	2	KNOB FEMALE M10x1.5 52X30mm
	6152108	2	DETENT PIN

FITTING PROCEDURE

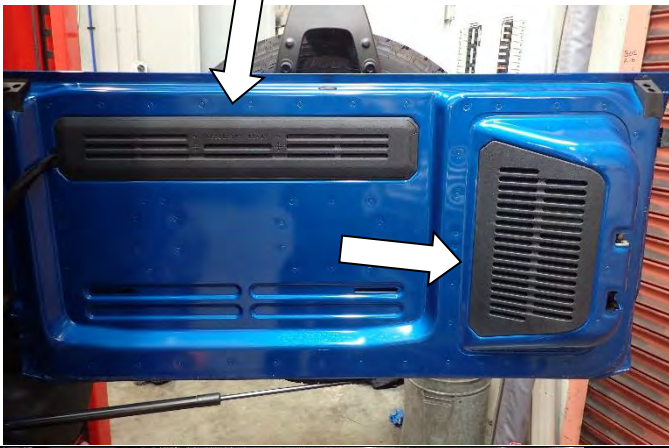

1. Remove both plastic rear door access covers starting at the bottom of each cover.



2. Remove lower door support and place aside with fasteners for reinstallation later.



3. Fit six black M6 cage nuts to main bracket.

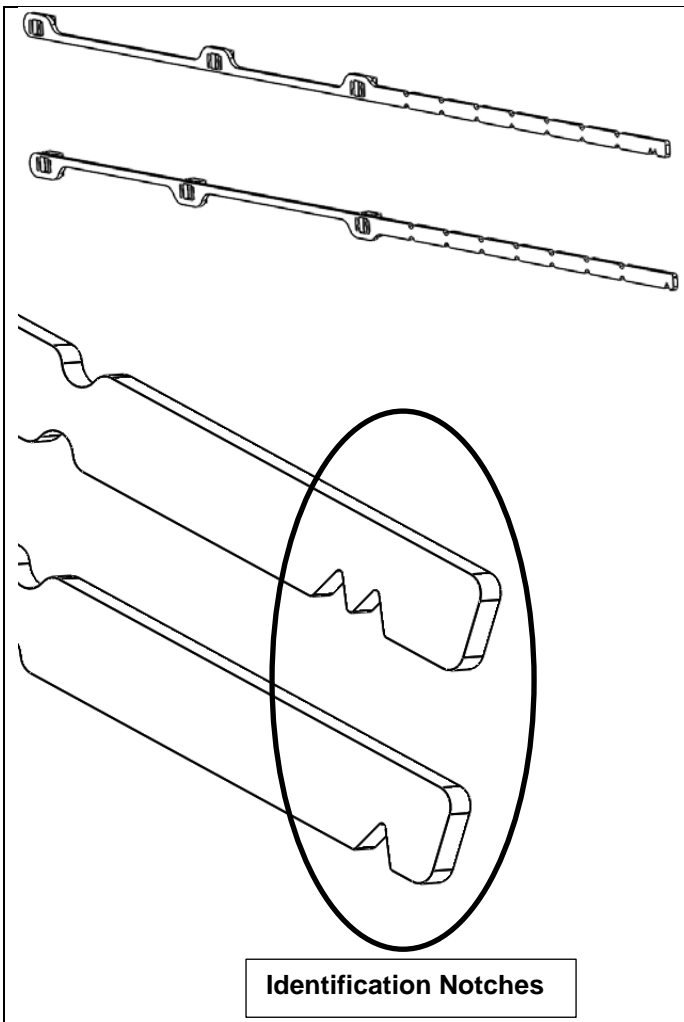

Identification Notches

4. Install eight silver M6 cage nuts onto nut sticks. (2 long and 2 short)



Correct alignment of cage nuts is as pictured, the tabs run in the same direction as the long edge of the nut sticks.

NOTE: If a cage nut gets removed from the nut stick during installation refer to rear wheel removal instructions on page 12.

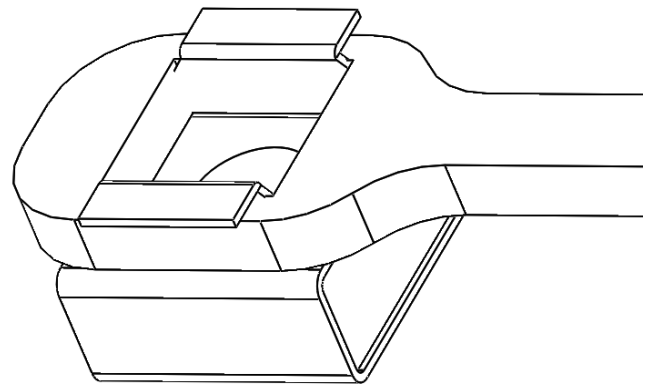

5. Feed nut stick with two identification notches up, through the opening for the door support until the cage nuts can be aligned with the top slots.

The nut sticks will need to be bent within the door cavity to achieve alignment to the slots.



6. Temporarily install an M6 bolt into the RHS cage nut as shown to hold the nut stick in position.



7. Starting at the LHS of the door, fit an M6 bolt and washer through the mount and into the cage nut. Do not tighten.
8. Remove the M6 bolt from step 6 and reinstall with an M6 washer through the mount.
9. Use a short nut stick for the RHS mounting hole with an M6 bolt and washer, the long nut stick will need to be bent out of the way.
10. Fit the remaining M6 bolt and washer on the top row.

Leave loose at this stage.



11. Insert the second long nut stick through the door support opening and align with the bottom row of holes on the mount.
12. Fit three M6 bolts and washers to the cage nuts starting from the LHS
13. For the RHS use 1 short nut stick and an M6 bolt and washer, the long nut stick will need to be bent out of the way.
14. Take care not to pinch the wiring loom, centralise the mount and tighten to specified torque.

 M6 – 9Nm – 7lbft



15. Re-install the door support and large plastic OE cover.
16. Fit the Logo cover panel to the mount using six M6 x 20 BHD screws and tighten to specified torque.

 M6 – 9Nm – 1lbft

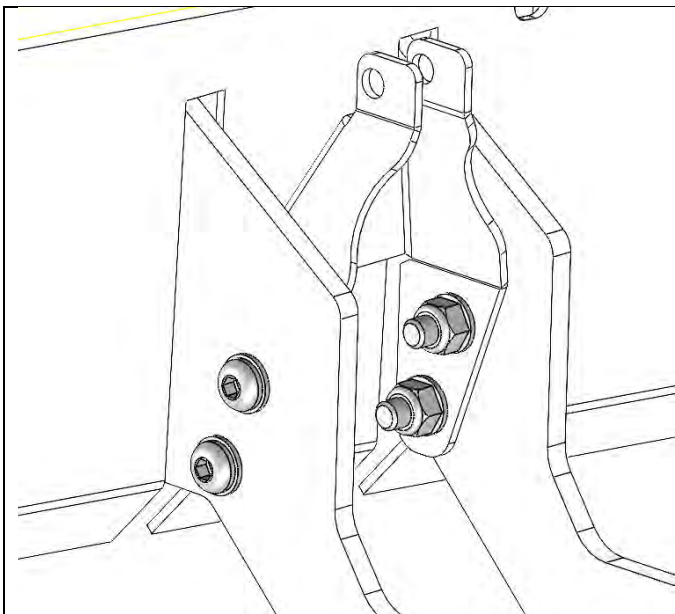

17. Use four M6 x 20 BHD screws, eight M6 washers and four M6 Nyloc nuts to assemble both Pivot shaft mounts onto bracket. Torque to specification.

 M6 – 9Nm – 7lbf

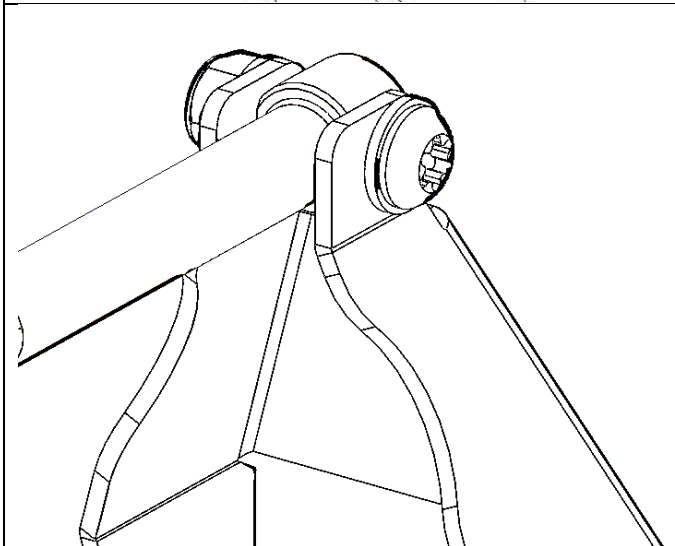

18. Install the threaded shaft using an M6 x 25 TORX screw, two M6 washers and an M6 Nyloc nut for each shaft. Shaft must pivot freely once fasteners are tightened.

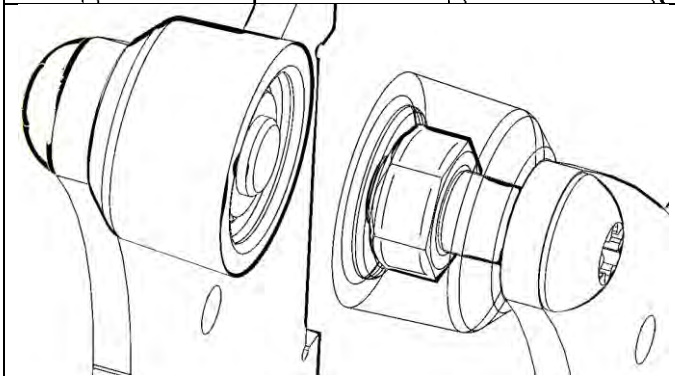

19. Insert an M10 nut into the rubber spacer bushes (2).

20. Using Loctite 243, install the rubber spacer bush and nut to the mount with an M10 x 25 BHD screw on each side.

21. Tighten until the rubber starts to deform.

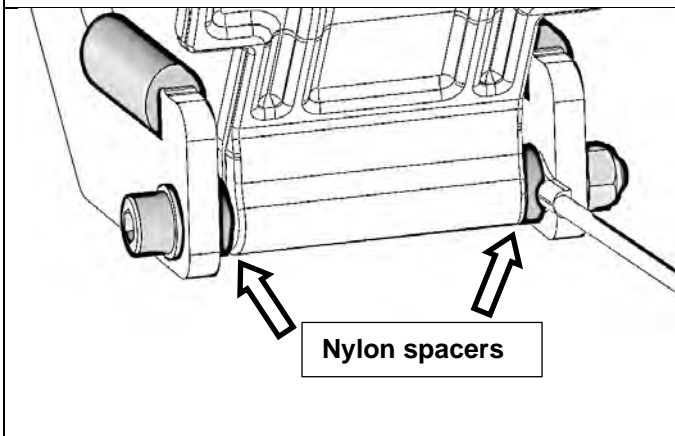

22. The shorter clamp fits onto the LHS with an M6 x 75 SHCS, two M6 washers, two nylon spacers, a lanyard and a Nyloc nut.

23. Fit the Nylon spacer to both the LHS and RHS of the clamp. The lanyard goes onto the RHS of the clamp between the nylon spacer and the mount.

24. Tighten fasteners enough to eliminate play but maintain smooth rotation of clamp.

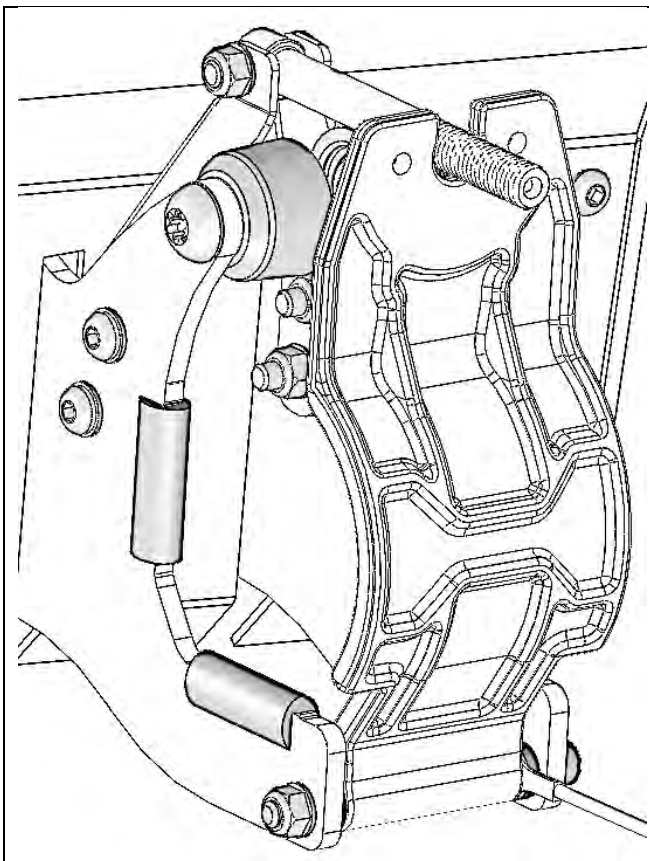

25. For the longer clamp repeat steps 22-24 to assembly to the RHS.

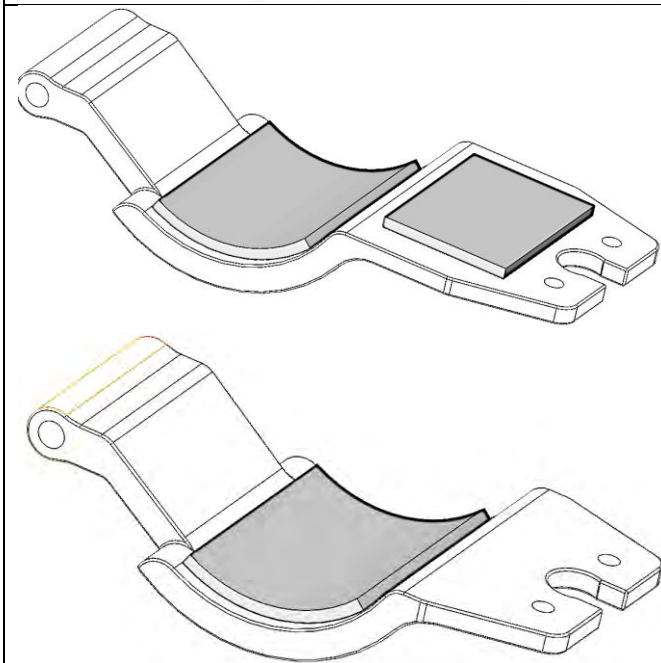

26. Fit rubber pads as shown .

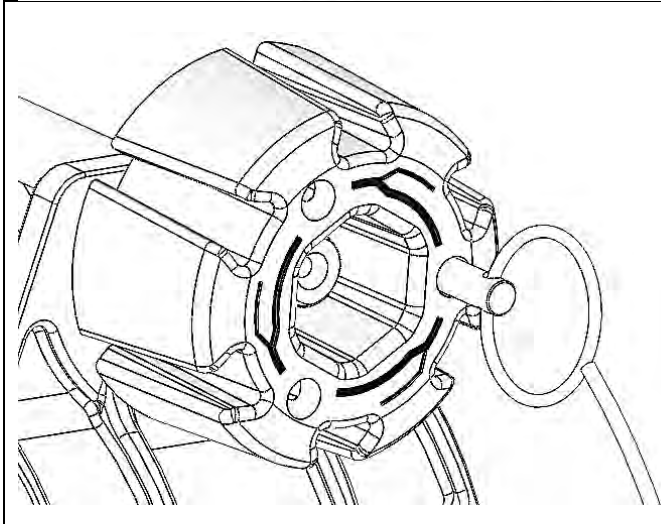

27. Fit knobs to threaded shafts and attach detent pins to lanyards.

USER INFORMATION

To load the ARB Jack onto the mount, rotate the 2 knobs to a vertical position and rotate both clamps downwards.

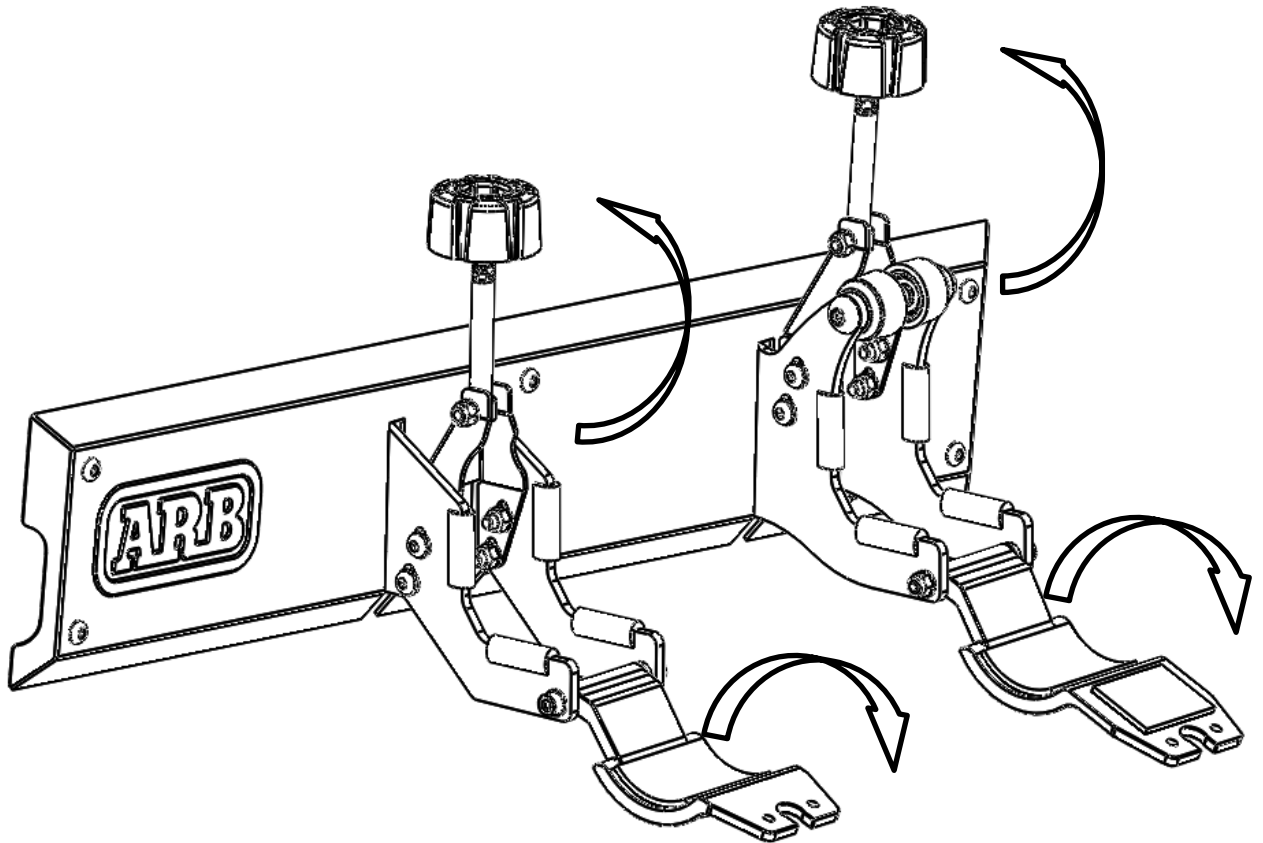

Sit Jack onto the mount.

Locate the 3rd and 4th slots onto the mount.

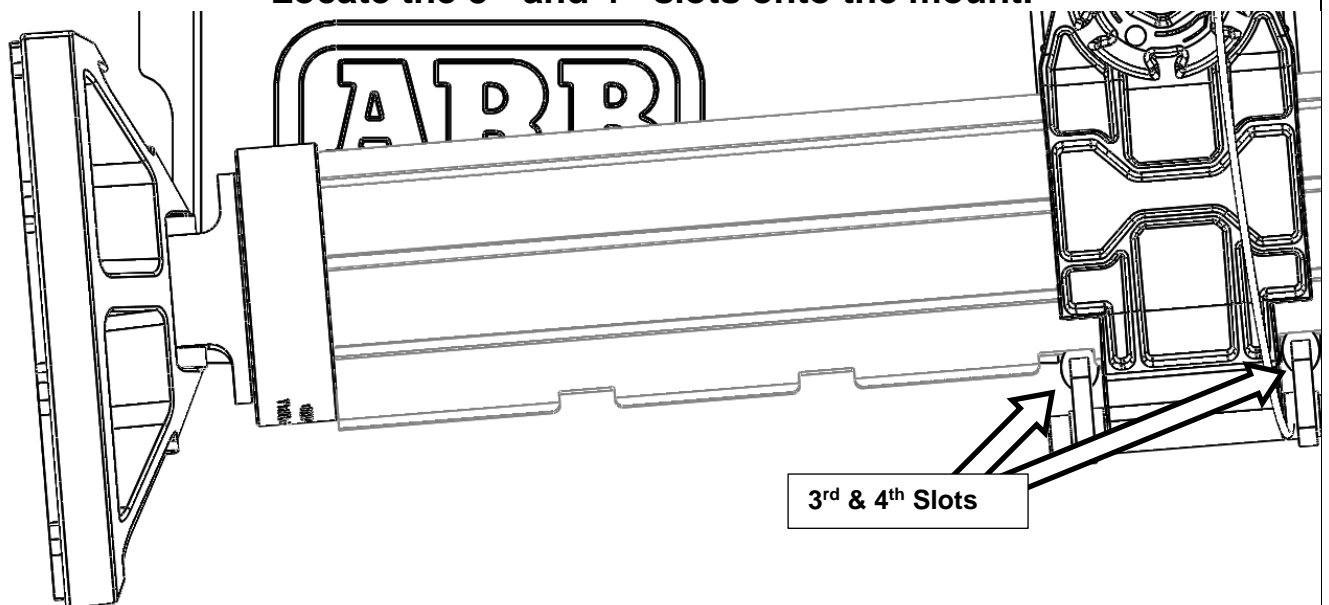

Rotate the 2 clamps up to contact the Jack.

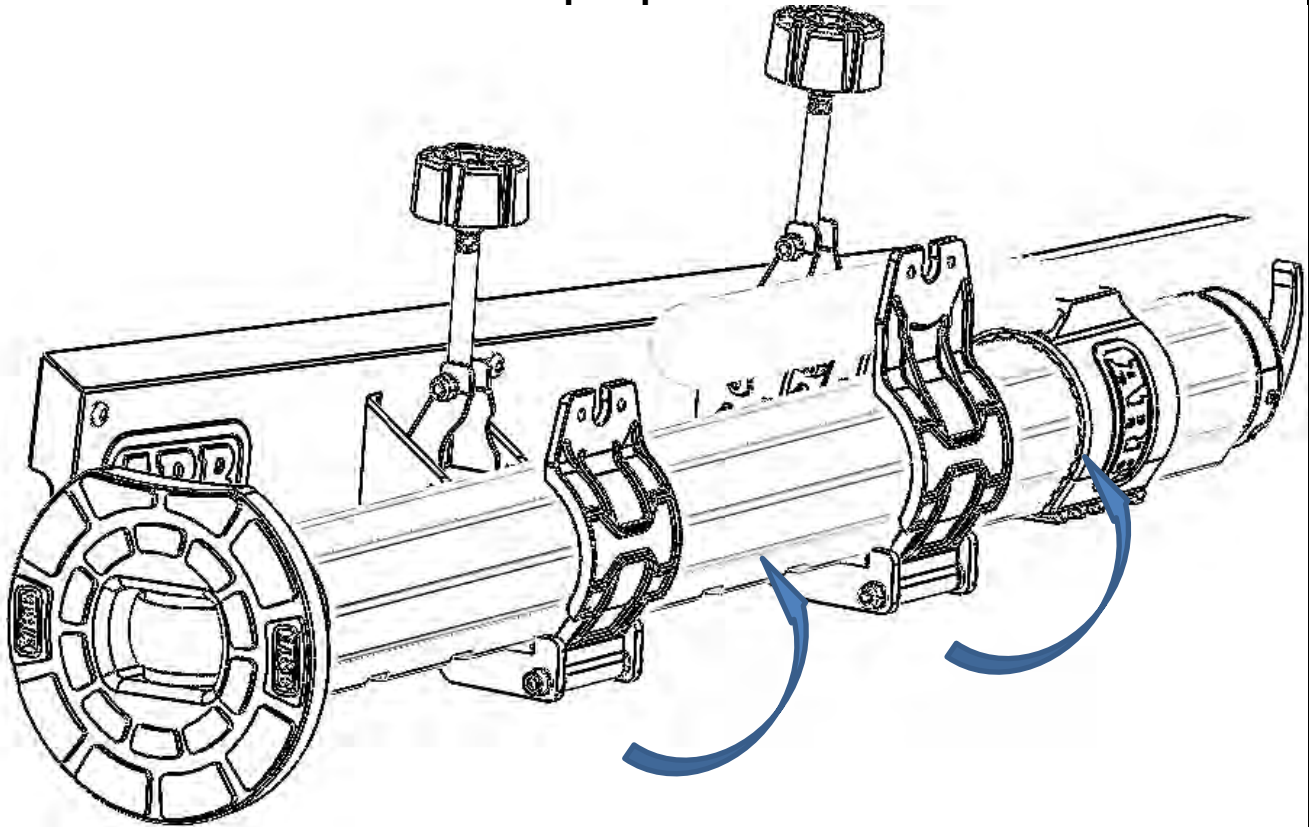

Bring the knobs down to the clamps.

The knob has a brass button that locates inside the slot on the clamps, this MUST be located correctly before tightening the knob.

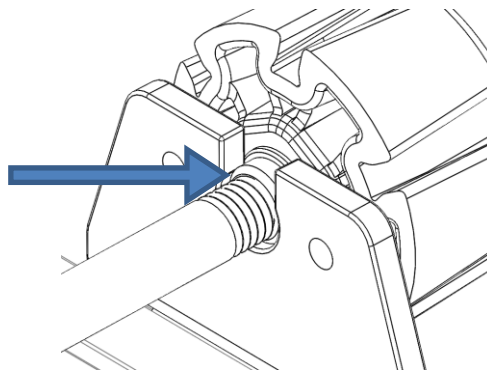
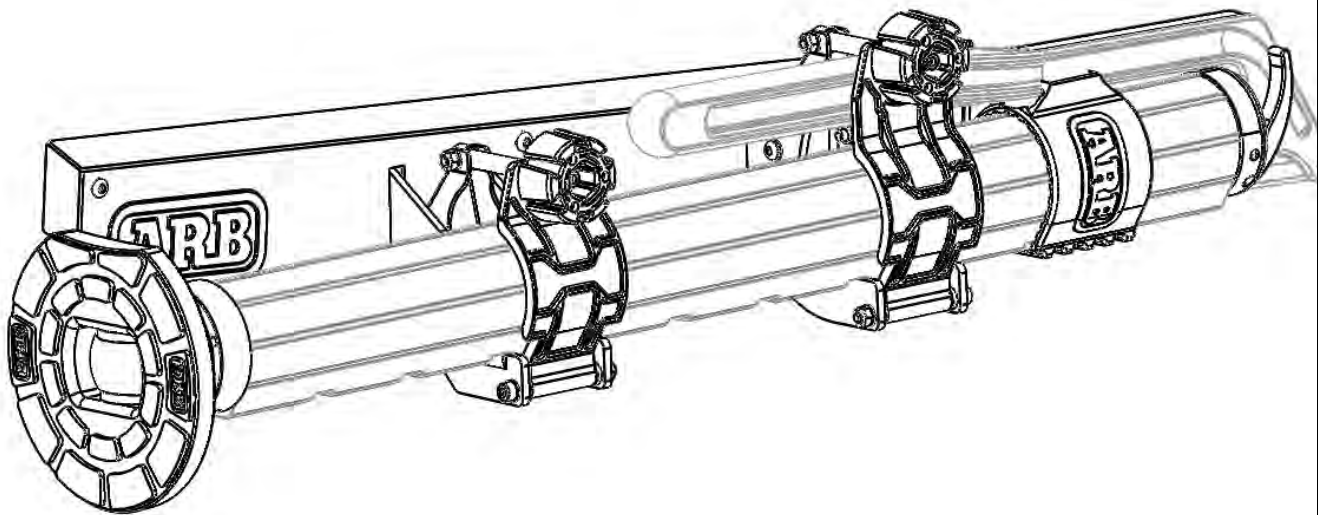

Tighten both knobs a further three and a half turns after initial contact of the knob to the clamp. Align the nearest hole in the knob with either hole on the clamp. Insert the detent pin through the aligned hole on the knob and clamp. Rotate the knob slightly again against the detent pin.

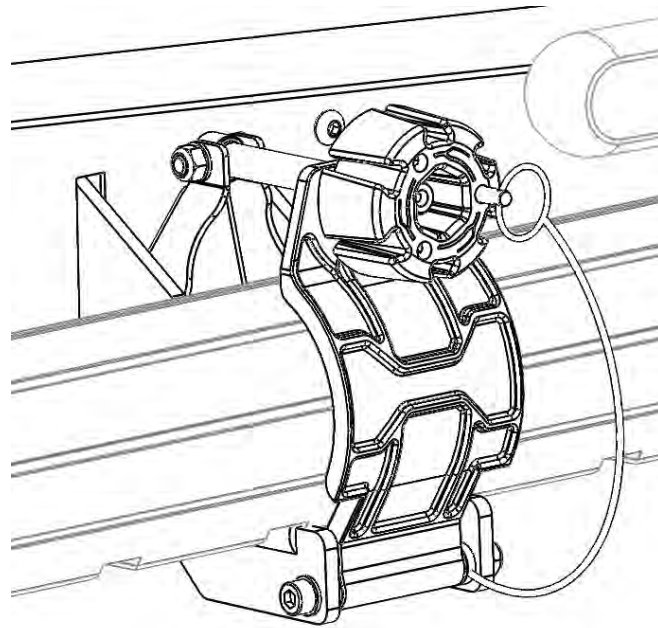

FITTED PRODUCT



SPARE WHEEL AND CARRIER REMOVAL FOR RETRIEVING LOST FASTENERS

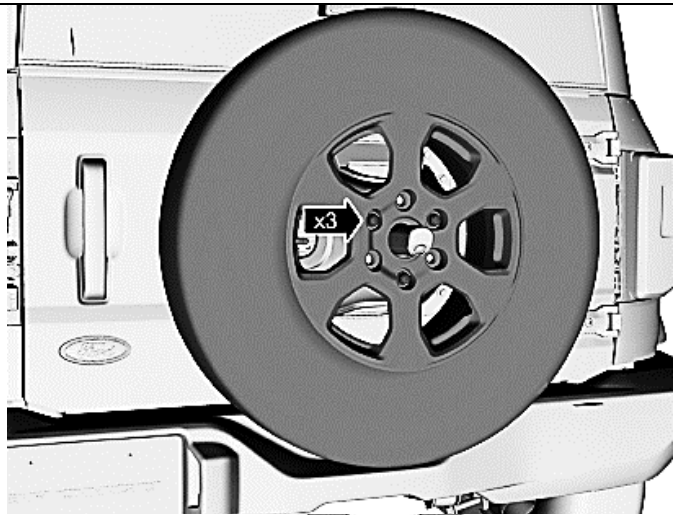

Remove the three wheel nuts and spare tire.

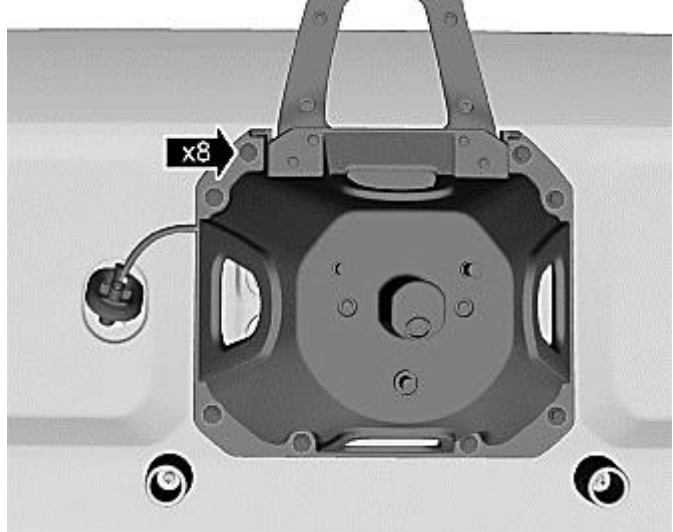

Remove the eight bolts retaining the spare wheel carrier.

Then remove the spare wheel carrier, support the carrier so the camera wiring does not get damaged.



Carefully remove the lower vent and extra piece of sound material to access the door cavity and retrieve any dropped items.



Reassemble in the reverse order.

FASTENER TORQUE SETTINGS:

SIZE	Torque Nm	Torque lbft
Wheel carrier bolts	25Nm	18lbft
Spare wheel nuts	133Nm	98lbft