



**Before returning this product
to the store of purchase**

Contact Dee Zee if you experience the following problems:

- Missing Parts
- Installation Problems/Questions
- Warranty Questions

1.800.779.2102

Hours of operation: 8am - 5pm CST, Mon-Friday

Review complete warranty policy and register your product at:

www.deezee.com/warranty.php



DZ 95053 – Half Ladder Rack

INSTALLATION INSTRUCTION MANUAL

Please read this manual carefully before installing the ladder rack.

This manual contains important safety and maintenance instructions.

WARNING—Failure to follow or comply with all warning & instruction in this manual may result in equipment damage, or serious bodily injury.

WARNING—Our ladder rack is only intended, and only safe for transporting ladder, lumber, pipes and other similar materials. It is the user’s responsibility to ensure that the materials being transported is safely secured on the rack before transportation. Any use of this product for other purposes, or modifications made to this product can cause serious bodily injury or property damage.

CAUTION—To prevent resonant vibration damage during driving with unloaded racks, the leg assembly should be removed.

TOOL REQUIRED

- Electric drill w/1/2” & 7/32” drill bits
- Screwdriver-straight
- Framing square
- Center punch
- Hacksaw
- Ruler
- Tape

WARNING- Prior to drilling, check under vehicle for proper locations to avoid puncture, but or damage fuel tank, fuel lines, brake lines, electric wires, etc.

WARNING- Always wear protective eyewear to keep debris out of your eyes when checking underside of the vehicle, and when drilling.

Hardware Kit

	BOLT			Nylon Locking Nut	Flat Washer		Lock Washer
	TYPE	SIZE	QTY	QTY	SIZE	QTY	QTY
A	Carriage Bolt	M10×80	1	1	Ø25	1	0
B	Hex Bolt	M8×30	9	0	Ø25	9	9
D	Carriage Bolt	M10×20	2	0	-	0	0
E	Blind Fastener			9	-	-	-
F	Installation Bolts & Tool	M8×55	1set	-	-	-	-

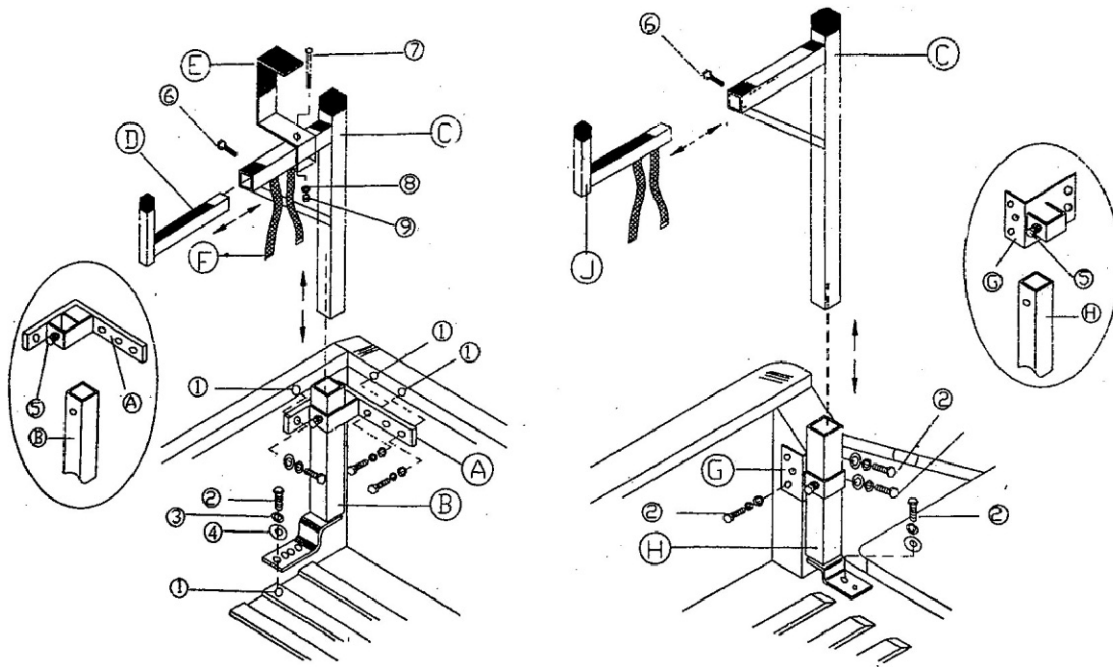

ASSEMBLY INSTRUCTIONS –FRONT OF TRUCK BED

Note: This illustration shows installation on the passenger side for the front leg. If installation is intended for the driver side, simply reverse the parts.

Note: If your pick up has a bed liner, you may need to trim, drill or cut the liner for proper and secure installation of the aluminum ladder racks.

Note: If the best mounting hole location is between floor spacer and/or extra 5/16" flat washers have been provided to fill the void. Or rotate the leg socket 90 degrees to the rear of the vehicle if possible.

OTHER DETAILS

Installation of blind fastener

Drill 1/2" hole for blind fastener

Place a drop of oil on the black oxide bolt before assembling as shown on the left.

Place the blind fastener in the hole and use a 1/2" or 7/16" wrench to tighten black hex bolt until the blind fastener is fully sealed. When setting black hex bolt, it will start out hard. As the blind fastener "bulbs" out, it will get easier. Make sure that the

blind fastener and Installation tool does not turn during installation.

Installation of Rope cleat

The two rope cleats are to be mounted where desired.

HEIGHT OF LADDER

Place a ladder on the rack, and check door entry/head clearance. If there is ample clearance, and if desire, the rack legs may be shortened as long as a minimum clearance of 2” above the cap roof with the ladder is maintained. Remove and cut the legs if desired.

Note- cut tubing from the bottom of the legs. Double check the measurement before cutting.

WARNING Ladders must be secured per ANSI standard A 14.2-1990 paragraph 8.4.4.ladder damage will occur from road shock and vehicle vibration if the ladder is not properly secured to the ladder rack. Bouncing and side to side motion of a improperly secured ladder will cause wear and weaken the ladder. Using a damaged ladder could lead to a structural collapse and could result in a serious injury or death.

Warning:

- Make sure all hardware connections are secure before each use.
- Do not exceed 200 pound weight Limit
- Do not use if restricts your vision or safe driving.
- Always check rack does not un-balance Vehicle in use.
- ALWAYS OBEY ALL LOCAL, STATE AND FEDERAL TRAFFIC LAWS.
- UNDER NO CIRCUMSTANCES SHOULD THIS PRODUCT BE USED TO TRANSPORT PEOPLE OR LIVING ANIMALS.
SERIOUS INJURY OR DEATH MAY RESULT
- USER IS RESPONSIBLE FOR THE SAFE LOADING AND UNLOADING OF THIS PRODUCT. BE SURE TO USE CAUTION
WHEN STRAPING DOWN LOADS OR LOOSE ARTICALES.

Congratulations on the purchase of this fine Dee Zee Product! Please visit www.deezee.com for a full line of our high quality products offered at your local Dee Zee retailer.

DEE ZEE, INC WARRANTY AGREEMENT

Dee Zee, Inc guarantees the original purchaser a limited lifetime warranty against manufacturer defects in materials, workmanship and design under normal use excluding damage resulting from road hazards such as gravel or other debris, product misuse, improper installation, impairments from accidents, product modifications, spills, vandalism, or product neglect. Wear items such as shocks, latches, keys, hinges, step pads, seals, etc have a one-year warranty. This warranty applies only to new products and is limited to the repair or replacement of genuine Dee Zee products. Warranty does not include electrical components, light bulb replacement, and cost of removal, installation, labor, transportation costs, and loss of use, inconvenience or consequential damages. Modifications of any kind to a Dee Zee product void all warranties. The original purchaser may be required (at Dee Zee's sole discretion) to return the defective merchandise, provide a photograph, or provide the original purchase receipt to the original place of purchase or Dee Zee, Inc.

WARRANTY TERMS

LIMITED-LIFETIME WARRANTY ON THE FOLLOWING PRODUCTS, INCLUDING:

- **STAINLESS STEEL: SIDE STEPS, GRILLE GUARDS, BULL BARS, BED CAPS, STORAGE BOXES, AND SIDE MOLDINGS.**
- **ALUMINUM: SIDE STEPS, STORAGE BOXES, RUNNING BOARDS, TRANSFER TANKS, BED PROTECTION, AND CAB RACKS.**
- **PLASTIC: STORAGE BOXES, BED CAPS, AND RUNNING BOARDS.**
- **OTHER PRODUCTS: BED MATS, AND RUBBER MUD FLAPS.**

THREE-YEAR WARRANTY ON OTHER PRODUCTS, INCLUDING:

- **POWDER-COATED / E-COATED STEEL: SIDE STEPS, STORAGE BOXES, JOB SITE BOXES, AND TRANSFER TANKS.**
- **OTHER PRODUCTS INCLUDING: EZ DOWNS, FLOOR MATS, BULBS, RUNNING BOARDS, AND PRODUCTS NOT OTHERWISE LISTED SEPARATELY.**

TRANSFER TANK PUMPS & ACCESSORIES

ALL GPI PRODUCTS INCLUDING TRANSFER TANK PUMPS AND RELATED ITEMS ARE COVERED BY THE GPI WARRANTY. TO SUBMIT A WARRANTY CLAIM, PLEASE CONTACT GPI AT 800-835-0113. DEE ZEE, INC WARRANTY TERMS DO NOT APPLY TO GPI PRODUCTS. YOU MAY ALSO VISIT: WWW.GPI.NET.

FINISH PROTECTION

Dee Zee products have a high quality finish that must be cared for like any other exposed finish on the vehicle. Protect the finish with a non-abrasive automotive wax, (e.g. Pure Carnauba) on a regular basis. The use of any soap, polish or wax that contains an abrasive is detrimental, as the compounds scratch the finish and open it to corrosion. The finish of all Dee Zee products is covered for 1 year from the date of purchase. Claims submitted after one year from the date of purchase are subject to review, and are covered at the sole discretion of Dee Zee, Inc.

Disclaimer

Buyer assumes all risk and liability for the installation and use of Dee Zee products. Dee Zee products are sold as appearance accessories and should not be relied upon as protection for the vehicle or its occupants in the event of a collision or roll over. Vehicles equipped with a supplemental restraints system (air bags) deployed by impact should not be modified in any way. Always consult the vehicle manufacturer if you have any questions regarding supplemental restraint systems. Dee Zee, Inc assumes no liability for injury, loss, incidental or consequential damages in the event of an accident.

WARRANTY SUBMISSION PROCEDURE

In order to ensure a prompt and efficient review of your claims, please review the following procedure before submitting your claim:

- 1) You must register your product at www.deezee.com/warranty
- 2) Please read the above terms and conditions to ensure that your product is eligible for warranty coverage.
- 3) Contact us at 1-800-779-2102 (You may be directed back to the original place of purchase).

4) Be sure to have your original receipt, and be prepared to describe the issue. Photographs may be required.