



PART NUMBER: EXF99CC-TX , EXF99QC-TX  
 PRODUCT: EPYX HOOP STEP  
 APPLICATION: 99-16 FORD F-250/350 CC/QC



PARTS INCLUDED	QTY
Step Rail	2
Rocker Panel mounting Brackets	6

HARDWARE DESCRIPTION	QTY.
# HWKT-00040X	
3/8 CLIP SHORT	6
3/8 X 1 HEX BOLT	6
3/8 USS FLAT WASHER	12
3/8-16X1 1/2 CARRIAGE BOLT ZNC	6
3/8-16 HEX FIN NUT ZNC	6
3/8" x 3/4" carriage bolts	12
3/8" Flanged nuts	12

**DO NOT USE IMPACT TOOLS**

**Step 1:** Locate the driver side step rail.

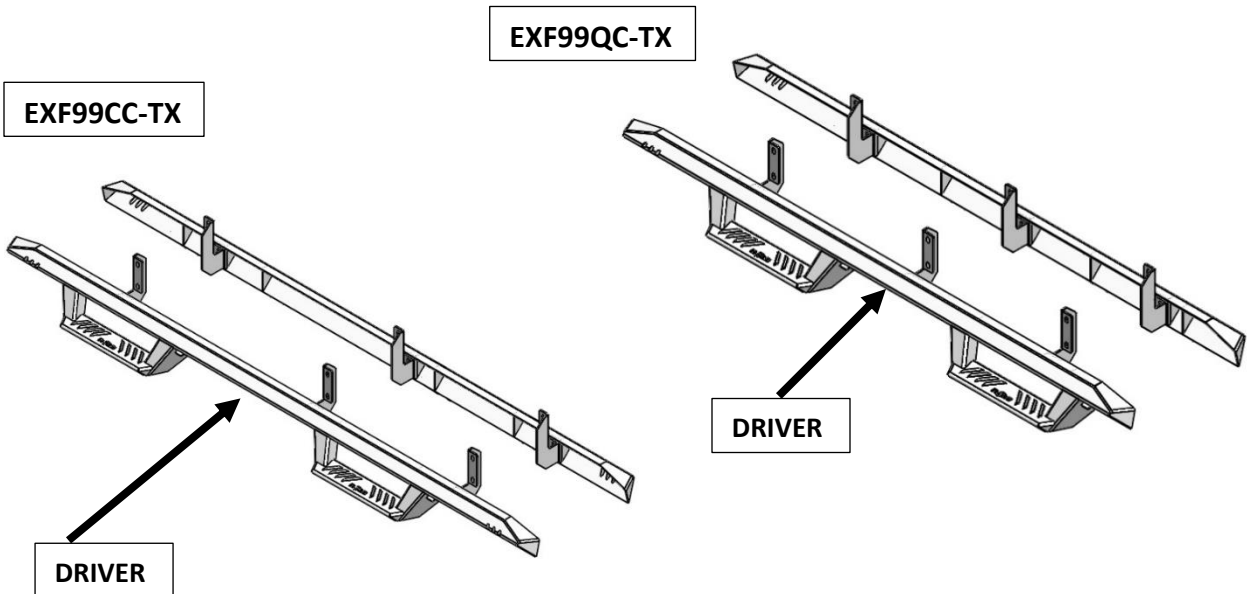

**Step 2:** Install three rocker panel brackets to the attachments points located on the backside of the channel using the supplied 3/8" x 3/4" carriage bolts and 3/8" flanged nuts. Leave finger tight for now.

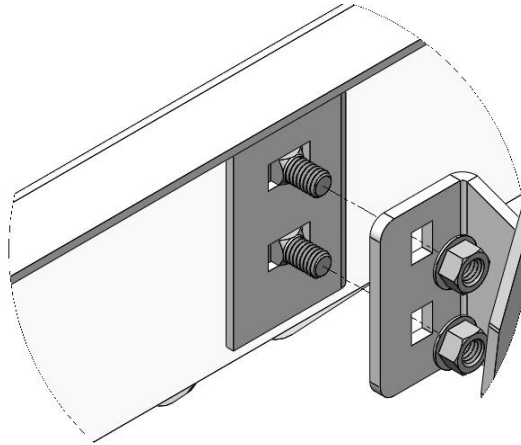

**Step 3:** Remove any factory-equipped running boards, fasteners, and discard.

**Step 4:** Locate the holes for the upper mounts (x3) and install the supplied 3/8" clips in each position. **NOTE:** There will be four attachment points in the rocker panel. Start with the second mount from the front that is located under the Driver door.

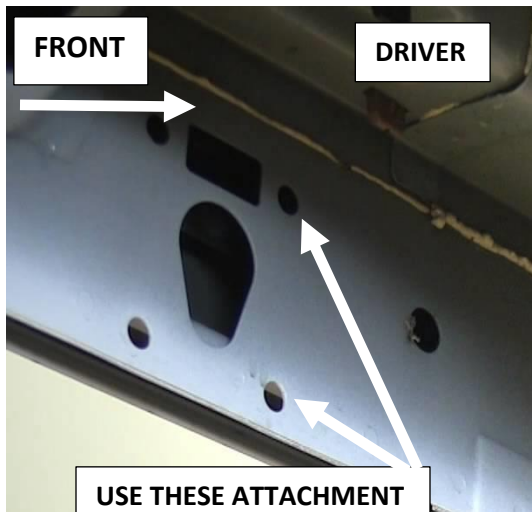

USE THESE ATTACHMENT POINTS FOR ALL THREE MOUNTS.

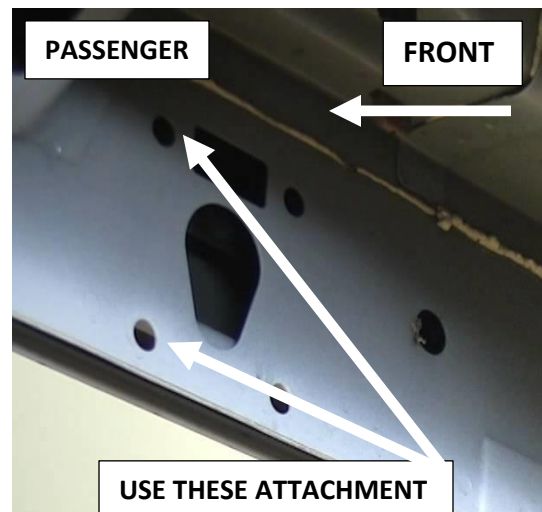

USE THESE ATTACHMENT POINTS FOR ALL THREE MOUNTS.

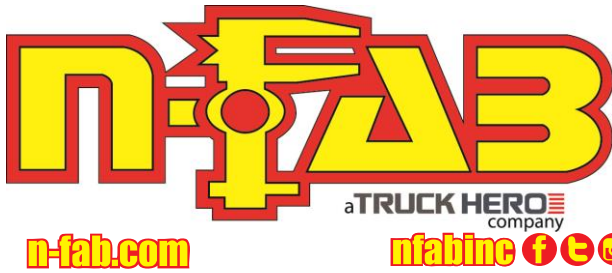

PART NUMBER: EXF99CC-TX , EXF99QC-TX  
PRODUCT: EPYX HOOP STEP  
APPLICATION: 99-16 FORD F-250/350 CC/QC

**Step 5:** Raise the step up into position and align brackets up to the three mounting positions and start the supplied 3/8" carriage bolts, nuts and washers and leave loose. **NOTE: The carriage bolts will start from the outside of the body where the nut and washer will be only visible from the opposite side of the pinch weld.**

**Step 6 :** Next, adjust the step assembly up/down and front/back to level out the step rail with body panel and then tighten step to brackets at 30 ft. /lbs.



**Step 7:** Starting with the rear bracket, carefully push up from the bottom and position the rail snug under the body of the vehicle and tighten only one of the carriage bolts.

**Step 8:** Next, move to the front bracket and push from the bottom to level the rail with the pinch weld. Completely tighten the hardware on all three brackets at 17-21 lb/ft of torque.

**Step 9:** Repeat steps 2-5 for the passenger

