

HARDWARE DESCRIPTION		QTY.
HWKT-05693X		
FLHB-00688	3/8"-16 X 1" GR. 5 HEX SERRATED FLANGE BOLT	12
FLNT-00696	M8-1.25 CLASS 8 SERRATED FLANGE NUT	12

PARTS INCLUDED	QTY
Running Boards	2
Rocker Panel mounting Brackets	6
Threaded clamp plates	6

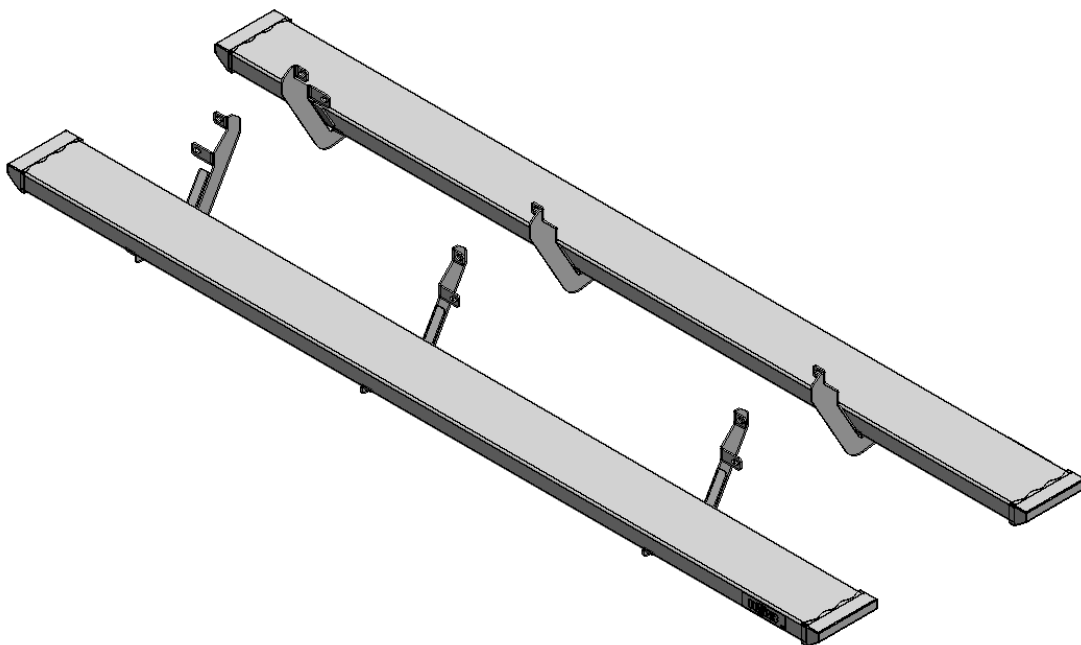

GROWLER



Step 1: Starting with the Driver Side. Remove all 8mm flange nuts from the 8mm factory threaded studs to remove the OE running boards. Repeat for passenger side.



Step 2: Install three of the supplied mounting brackets (both sides) to the factory locations and loosely fasten with the M8 flanged nuts.

*** BRACKET ORIENTATION ***

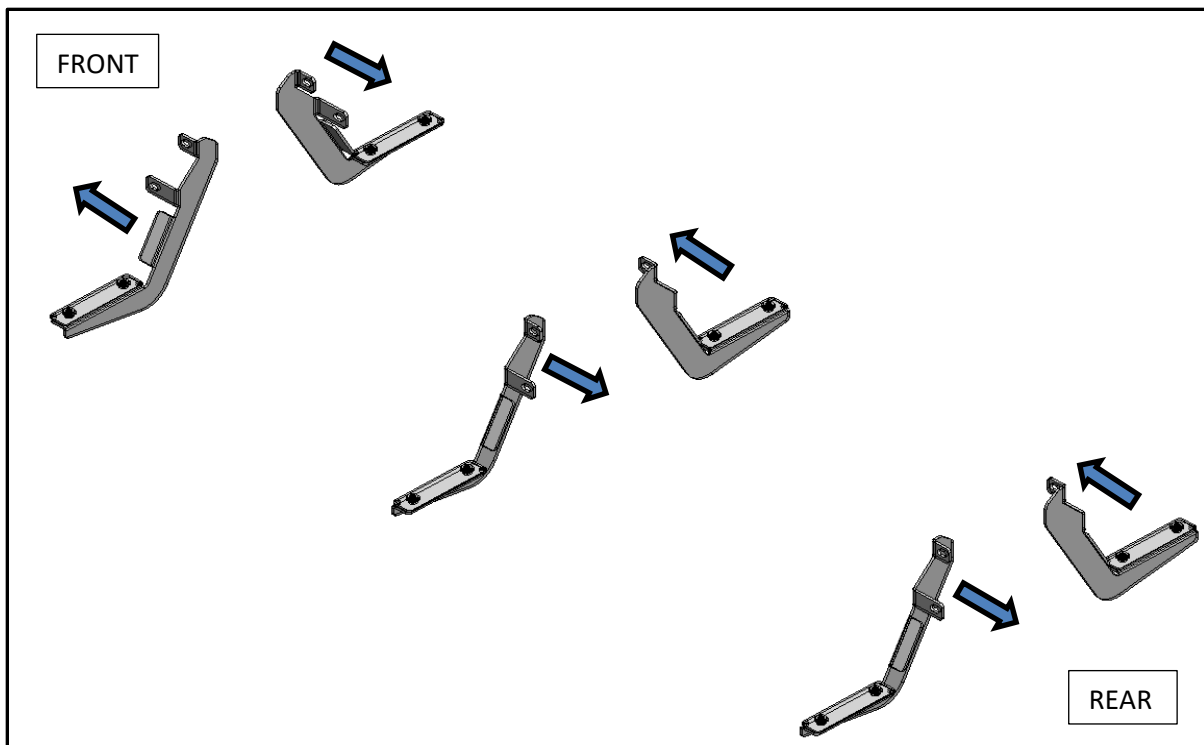

Step 3: Set running board along the top of the three brackets and center along the cab.



Step 4: Insert the supplied threaded brackets (X3) inside the running board lip over the top of each bracket.

Step 5: With the supplied 3/8" x 1" hex bolts, secure each mounting location and leave loose.

Step 6: After final adjustment, tighten all running board threaded mounts.

Step 7: Next, adjust frame brackets so the running board is level with body of the vehicle and tighten all factory-mounting locations.



Step 8: Repeat steps 3-7 for passenger side. Your install is now complete.



I-SHEET NUMBER: **INST-00012**
PART NUMBER: **GFF15-CCTX**
PRODUCT: **Growler Running Board**
APPLICATION: **2015-18 F-150**
2017-18 F-250, F-350