



INSTALLATION INSTRUCTIONS

Product: Rear Shock Relocation Bracket

Part Number: JKSOGS945

Applications: Wrangler JK, 2007+ (Rear Only)

517-278-1226 • tech@jksmfg.com • www.jksmfg.com
491 W. Garfield Avenue, Coldwater, MI 49036

Welcome

CONGRATULATIONS on purchasing a Rear Shock Relocation Bracket from JKS Manufacturing. We are committed to providing you with the best products available and your satisfaction is our first priority.

PLEASE READ these Installation Instructions carefully, and save them for future reference, as they contain important installation and maintenance information.

Important

NOT COMPATIBLE WITH aftermarket swaybars. Install product with Original Equipment swaybar only.

SOME VEHICLES MAY REQUIRE extended rear brake hoses or other modifications to compensate for additional suspension travel.

Tools Required

- Hydraulic Floor Jack & Jack Stands
- Metric / Standard Socket Wrench Set
- Felt Tip Marker
- Electric Grinder with 4" Cutoff Wheel & Flap Wheel
- Black Paint

* Asterisk denotes tools that are not required for some applications. Thoroughly read instructions first to determine which tools will be required for your application.

Parts

	Description	Part #	QTY
A	Shock Relocation Brkt - LH	03146	1
B	Shock Relocation Brkt - RH	03147	1
C	9/16"-18 x 4-1/2" bolt grade 8	18271	2
D	9/16" SAE flat washer thru-hardened	33245	4
E	9/16"-18 top lock nut	37310	2
F	3/8"-16 top lock nut	37264	4
G	3/8" SAE flat washer	33082	8
H	3/8"-16 x 1" bolt grade 8	15105	4

Installation

1. PREPARE AXLE

- Raise and support vehicle chassis with jack stands in front of the rear lower control arm pockets.
- Raise the rear axle with a hydraulic jack and disconnect the rear shocks and sway bar links from the axle, keep all hardware for reinstallation.
- Work on one side of the vehicle at a time.
- Remove the lower control arm on the driver's side, keep hardware for reinstallation.
- Use cutoff wheel to remove the factory sway bar link mount on the axle. Remove the factory shock bracket. Use flap wheel to smooth any remaining bracket material.

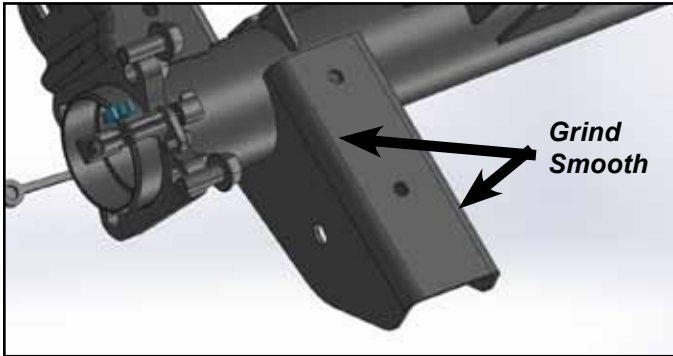

- Measure down from the factory lower control arm hole 1-3/8" and mark a horizontal line. Trim and remove this section from the vehicle.

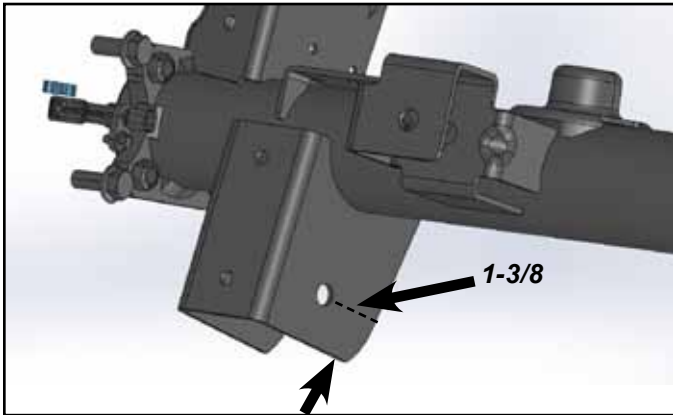

□ 2. BRACKET INSTALLATION

- Test fit the shock / sway bar relocation bracket (A). Clearance any area that interferes with the relocation bracket.

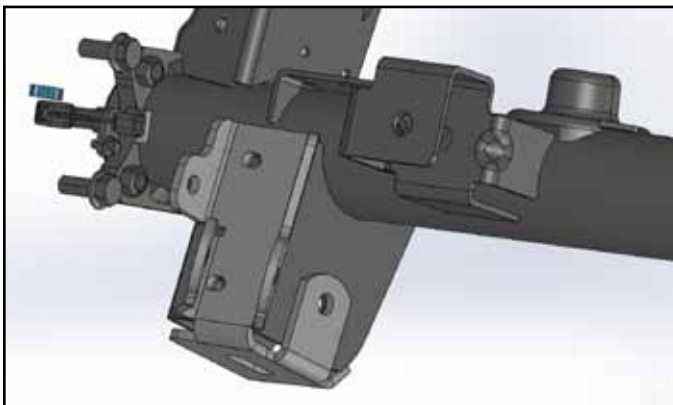

- Once the bracket fitment has been verified, remove bracket and coat area with paint.

□ 3. FINAL FITMENT

- Reinstall the lower control arm into the original pocket with new bracket (A), use new 9/16" x 4-1/2" bolt (C). Attach the bracket to the axle with 3/8" x 1" (H) bolt. Tighten 3/8" hardware to 35 ft-lbs. leave 9/16" loose at this time.

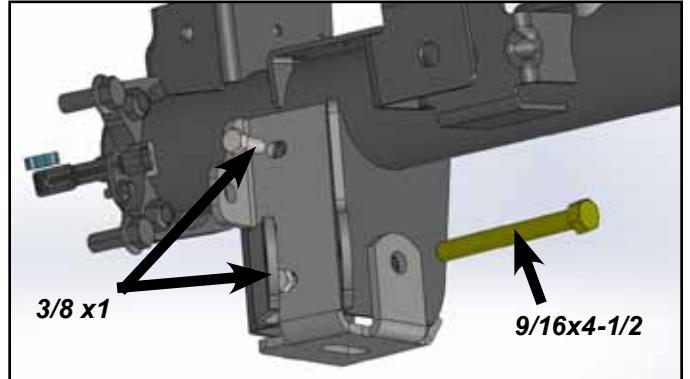

- Install lower shock and sway bar into relocation bracket with factory hardware. Tighten to 45 ft-lbs.
- Repeat installation on passenger's side using same steps outlined above.
- Allow axle to fully droop out, check for clearance between the tire and sway bar link. It may be necessary to purchase shorter shocks to limit droop, or purchase wheels with 4.5" of backspacing for additional clearance.
- Lower vehicle to the ground and tighten lower control arm hardware to 95 ft-lbs.
- Recheck all hardware for proper torque, check again after 500 miles.

©2013 JKS Manufacturing, Inc & Aftermarketing, LLC
Revision Date 11/1/2013