

# Firestone

## AIRIDE

riderite.com

# INSTALLATION INSTRUCTIONS

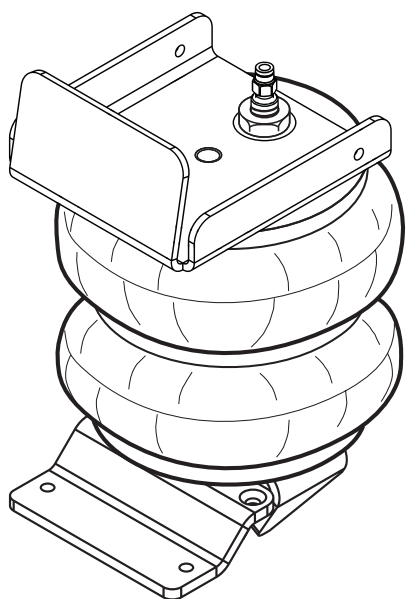

**SECTION 1 - AIR SPRING**

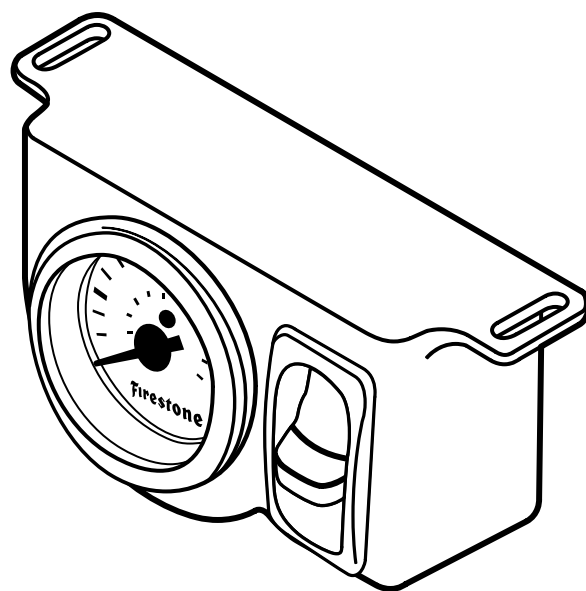

**SECTION 2 - AIR ACCESSORY**



[riderite.com](http://riderite.com)

# INSTALLATION INSTRUCTIONS



REQUIRES RIDE-RITE 2366 LIFT SPACER KIT (SOLD SEPARATELY) FOR INSTALL ON Z-71, HIGH COUNTRY, TRAIL BOSS, & AT4 MODELS.

THIS KIT IS NOT FOR SILVERADO LD OR SIERRA LIMITED MODELS. USE 2430 KIT.

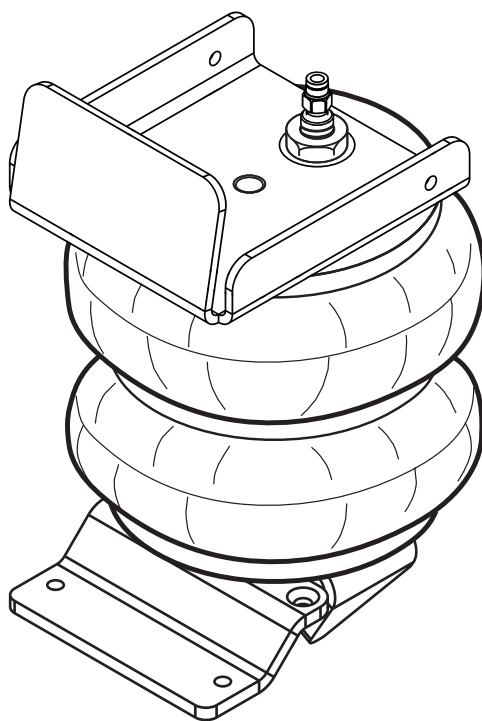

## Firestone

Firestone Industrial Products

# ! IMPORTANT

PLEASE DON'T HURT YOURSELF, YOUR KIT OR YOUR VEHICLE. TAKE A MINUTE TO READ THIS IMPORTANT INFORMATION.

This kit is to be used on a **pickup truck only**, and **DOES NOT INCREASE YOUR VEHICLE'S MAXIMUM LOAD**.

## **SAFE INSTALLATION**

Please take all safety precautions during installation. A hydraulic jack can fail, and if that happens, you can be seriously hurt, or worse, if you are relying on it to hold up the vehicle. If you use a hydraulic jack, secure jack stands in the appropriate locations and chock any tires still touching the ground.

Wear safety glasses or goggles. Your eyes may be lower than some parts and pieces, and you don't want to lose an eye.

Remove the possibility of any electrical issues by disconnecting the negative battery cable.

## **KIT CLEARANCE**

There must be a minimum of 1/2" clearance around all installed components when the air springs are inflated and under a load. The air springs must flex and expand during operation, so the clearance keeps the kit from rubbing against parts of the vehicle.

## **VEHICLE GVWR**

NEVER exceed the maximum load recommended by the vehicle manufacturer (GVWR). The GVWR can be found in your vehicle's owner's manual or on the data plate on the driver's side door. Consult your local dealership for additional GVWR specifications.

## **INFLATING THE AIR SPRINGS**

When inflating air springs, add air pressure in small quantities, checking air pressure frequently. The air springs have much less air volume than a tire, so they inflate much more quickly.

## **PRESSURE TO LOAD**

The air springs will support approximately 50 lbs. of load for each PSI of inflation pressure (per pair). For example, 50 PSI of inflation pressure will support a load of 2500 lbs. per pair of air springs.

## **APPROPRIATE AIR PRESSURE**

For best ride, use only enough air pressure in the air springs to level the vehicle when viewed from the side (front to rear). This will vary, depending on the load, location of the load, condition of the existing suspension, and personal preference.

## **OPTIONAL T-FITTING**



This kit includes inflation valves and air line tube for each air spring, allowing you to compensate for unbalanced loads. If you prefer a single inflation valve system to provide equal pressure to both air springs, your dealer can supply the optional "T" fitting (Part # 3025 or WRI-760-3461 retail pack).



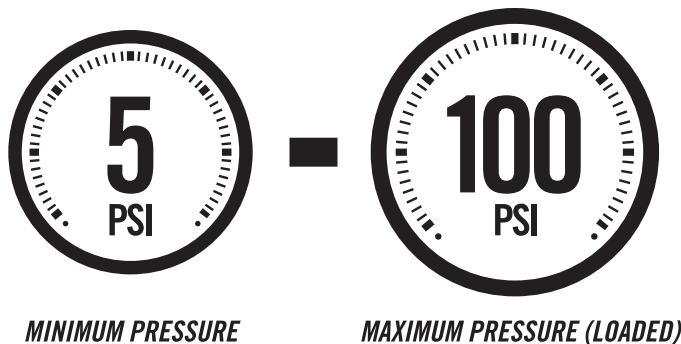

**ONCE INSTALLED SUCCESSFULLY, FOLLOW THESE PRESSURE REQUIREMENTS FOR THE AIR SPRINGS:**



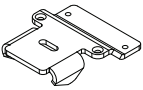

# PARTS

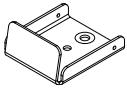
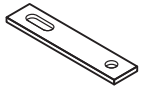
Compare the parts below to your kit. Ensure you have all pieces, and organize them for an easier installation.











## MAIN KIT CONTENTS

PT # 6397	 x2 AIR SPRING	PT # 5889	 x2 LOWER BRACKET	PT # 1004	 x1 HEAT SHIELD
PT # 5890	 x2 UPPER BRACKET	PT # 5041	 x2 BRACKET STRAP	PT # 9414	 x1 AIR LINE TUBE (18 FEET)

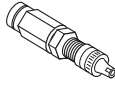
## A24-760-7560 INFLATION VALVE BRACKET KIT

PT # 9483	 x1 NO-DRILL INFLATION VALVE BRACKET	PT # 9488	 x2 LARGE NYLON TIE
-----------	---	-----------	---

## A21-760-2609 HARDWARE PACK

PT # 3033	 x4 5/16" FLAT WASHER	PT # 3358	 x2 M10 x 1.5 x 50mm FLAT HEAD SCREW	PT # 3510	 x12 1/4" - 20 FLANGE NUT
PT # 3069	 x2 3/8" - 16 x .75" FLANGE BOLT	PT # 3508	 x4 1/4" - 20 x 1 1/2" FLAT HEAD SCREW	PT # 3032	 x2 INFLATION VALVE AND VALVE CAP ASSEMBLY
PT # 3332	 x2 5/8" - 18 NYLON JAM NUT	PT # 3509	 x4 1/4" - 20 x 3/4" HEX HEAD SCREW	PT # 3055	 x2 1/8" NPT MALE CONNECTOR
PT # 0664	 x4 1/4" FLAT WASHER	PT # 3442	 x4 1/4" - 20 x 1 1/2" HEX HEAD SCREW	PT # 9036	 x6 RED NYLON TIE

## OPTIONAL ITEMS

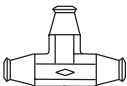
PT # 3025	 x1 T-FITTING
-----------	--

Visit [riderite.com](http://riderite.com) to find the perfect air accessories.

# CONTENTS AND OVERVIEW

PAGE **4** REMOVE JOUNCE BUMPER & INSTALL UPPER BRACKET

PAGE **5** PREP LOWER BRACKET ASSEMBLY & AIR SPRING

PAGE **6** INSTALL AIR SPRING TO LOWER BRACKET ASSEMBLY

PAGE **7** SEAT TOP OF AIR SPRING INTO UPPER BRACKET

PAGE **8** SECURE AIR SPRING TO UPPER BRACKET

PAGE **9** FINISH FASTENING THE AIR SPRING ASSEMBLY

PAGE **10** AIR LINE TUBE & INFLATION VALVE INSTALLATION

PAGE **11** INSTALL & ROUTE AIR LINE TUBE

PAGE **12** CHECKING THE SYSTEM

PAGE **13** FIXING AN AIR LEAK

PAGE **14** FINISHING THE INSTALLATION

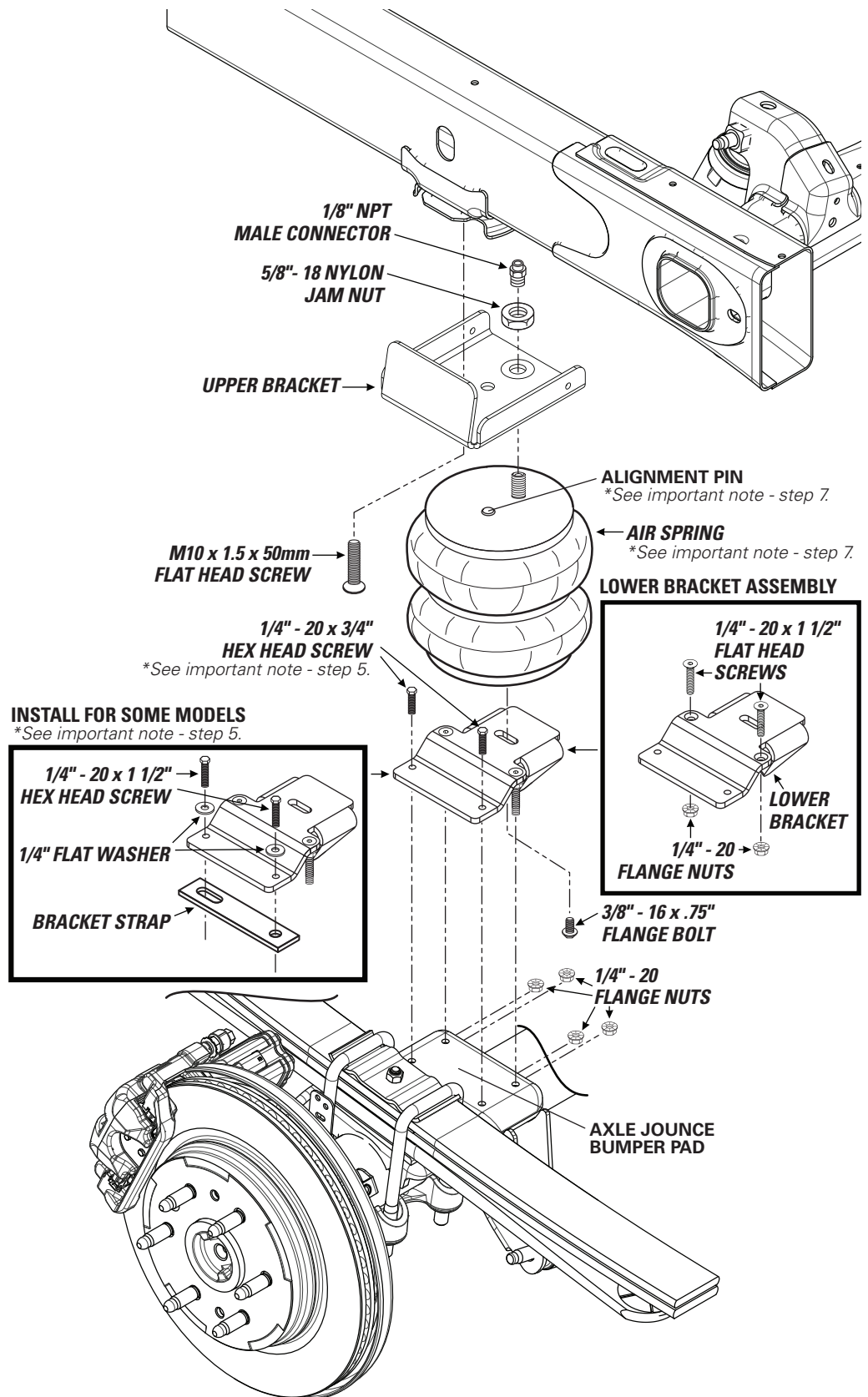

## REMOVE EXISTING JOUNCE BUMPER

1

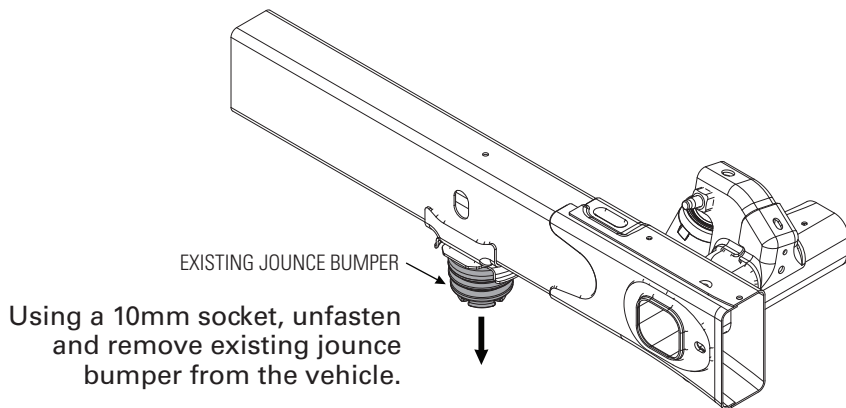

START THE INSTALLATION ON THE RIGHT SIDE OF THE VEHICLE WHEN FACING FORWARD.

## INSTALL UPPER BRACKET

2

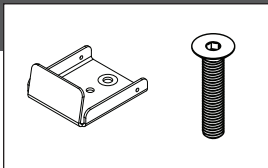

1 Place upper bracket against frame where jounce bumper was installed, assuring that the tab is on the outside of the frame.

2 Attach the upper bracket, as shown. Thread the flat head screw into the original jounce bumper bolt threaded hole and tighten to factory torque specifications.

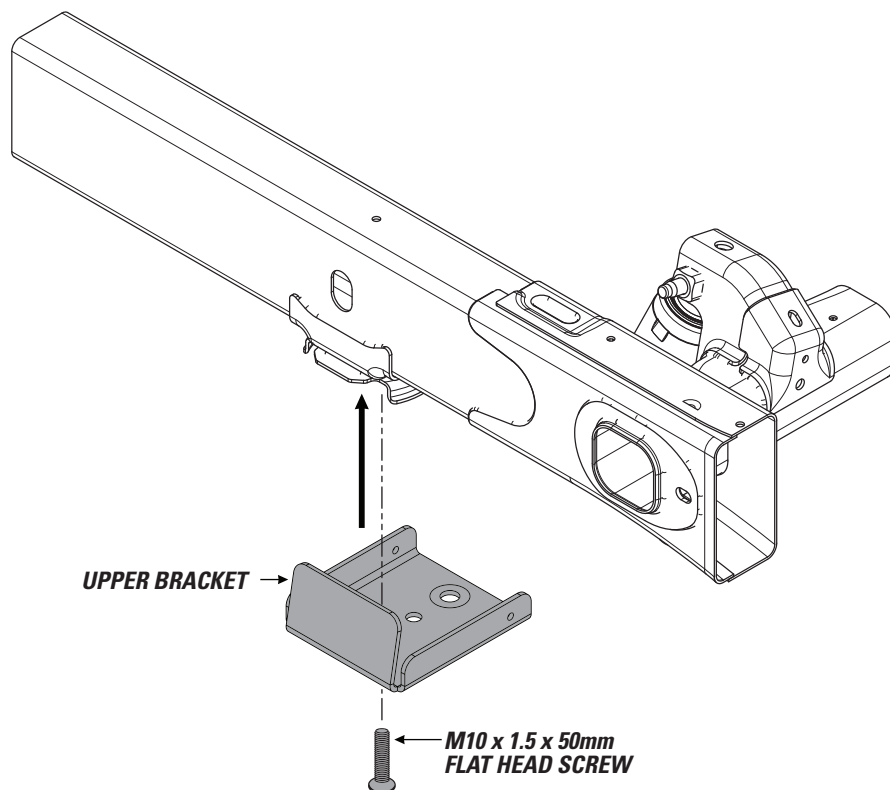

# 3

## PREP LOWER BRACKET ASSEMBLY

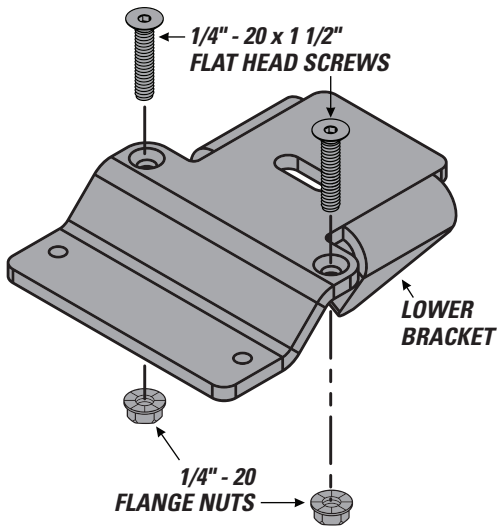
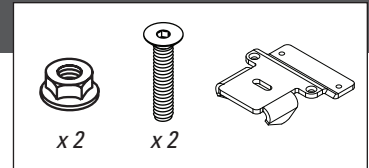

**1** Prep the lower bracket by installing the flat head screws and flange nuts, as shown.

# 4

## PREP AIR SPRING

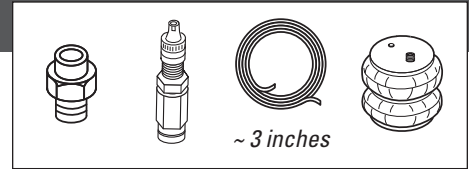

**1** Thread the 1/8" male connector into the combo stud on the air spring.

**2** Cut a short piece of air line tube (approx. 3 inches). Insert one end of the tubing into the 1/8" NPT male connector and the other end into the inflation valve.

**3** Using the inflation valve cap tool, depress the inflation valve pin and compress the air spring as much as possible. While holding the compressed air spring, release the inflation valve pin. The air spring will stay compressed and is ready for installation.

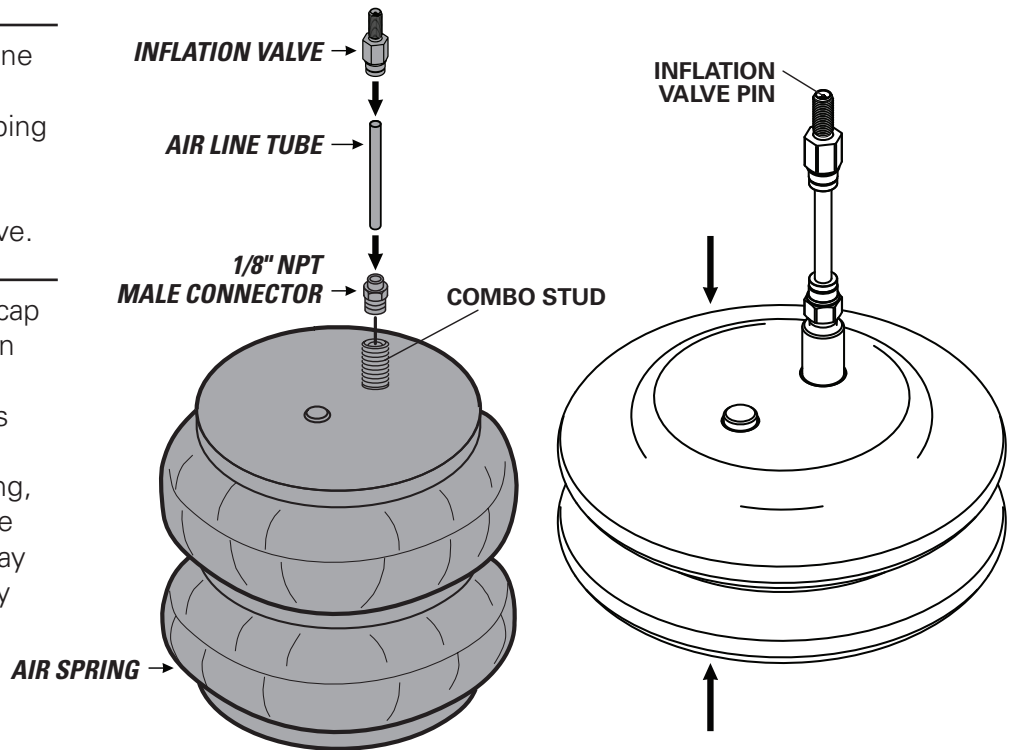

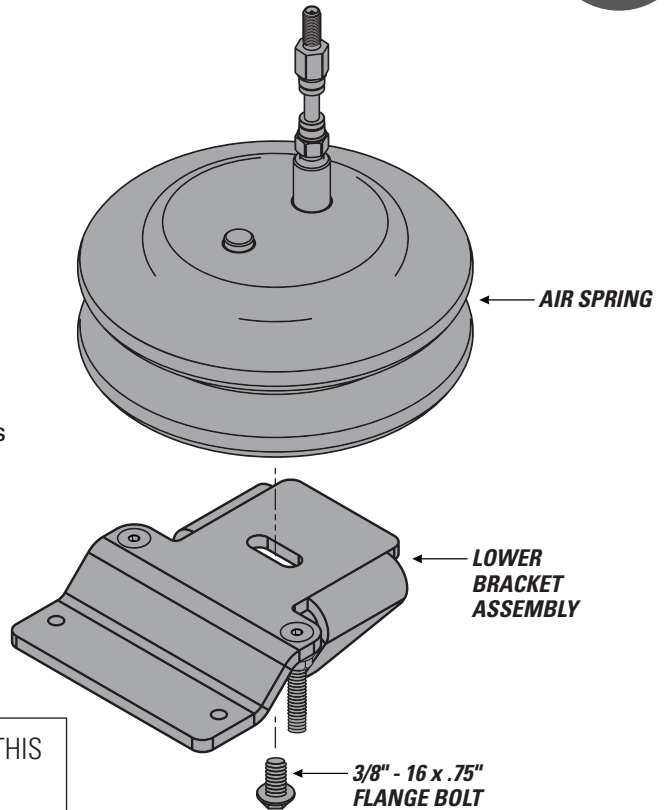
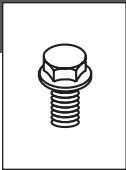

**1** Attach the air spring to the lower bracket, as shown. **DO NOT FULLY TIGHTEN THE BOLT.**



**DO NOT FULLY TIGHTEN THE BOLT AT THIS STAGE. TORQUE TO SPEC IN STEP 8.**

**2** Set the air spring assembly into place by inserting the two pre-installed screws into the inner two holes on the axle jounce bumper pad. See if the lower bracket rests evenly on the axle jounce bumper pad. If not, the bracket strap and associated hardware will be required in step 8.

**RIGHT SIDE VIEW FROM FRONT**

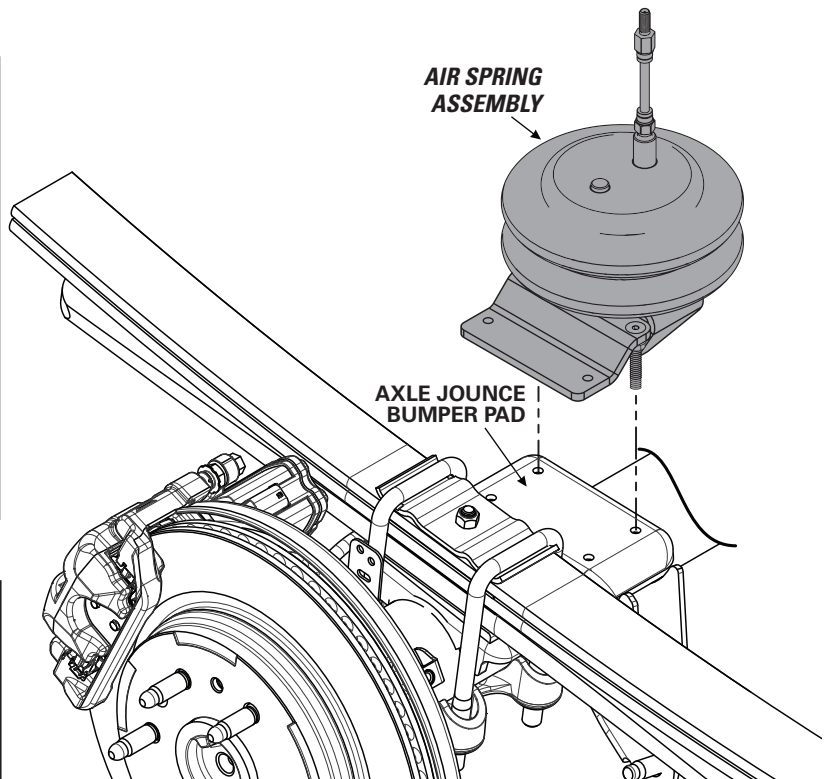
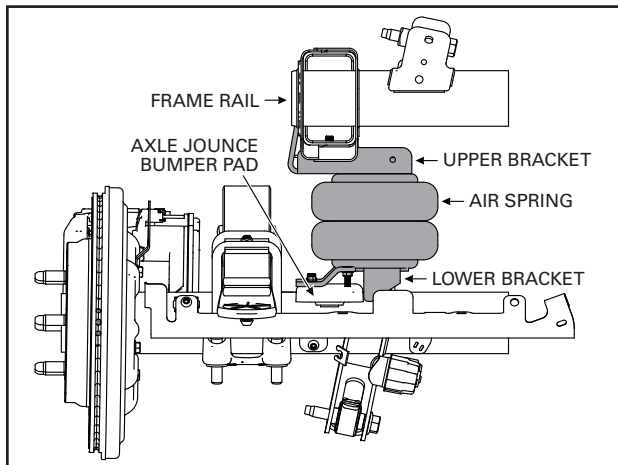

**SEE STEP 8 FOR DETAILS ON BRACKET STRAP**

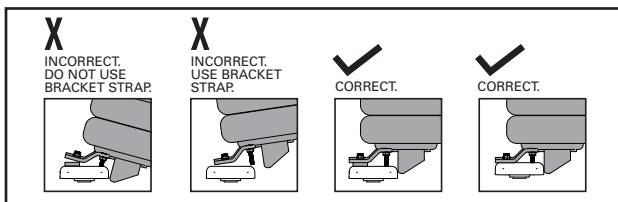



# 6

## SEAT TOP OF AIR SPRING INTO UPPER BRACKET



Right side only

**1** If installing the right side, install the heat shield, as shown. Position the heat shield so it is between the air spring and the nearest heat source.

**2** Guide the inflation valve and air line tube through the large hole in the upper bracket.

**3** While depressing the inflation valve pin to allow air into the air spring, rotate the air spring, if necessary, until the combo stud is fitted through the large hole in the upper bracket.

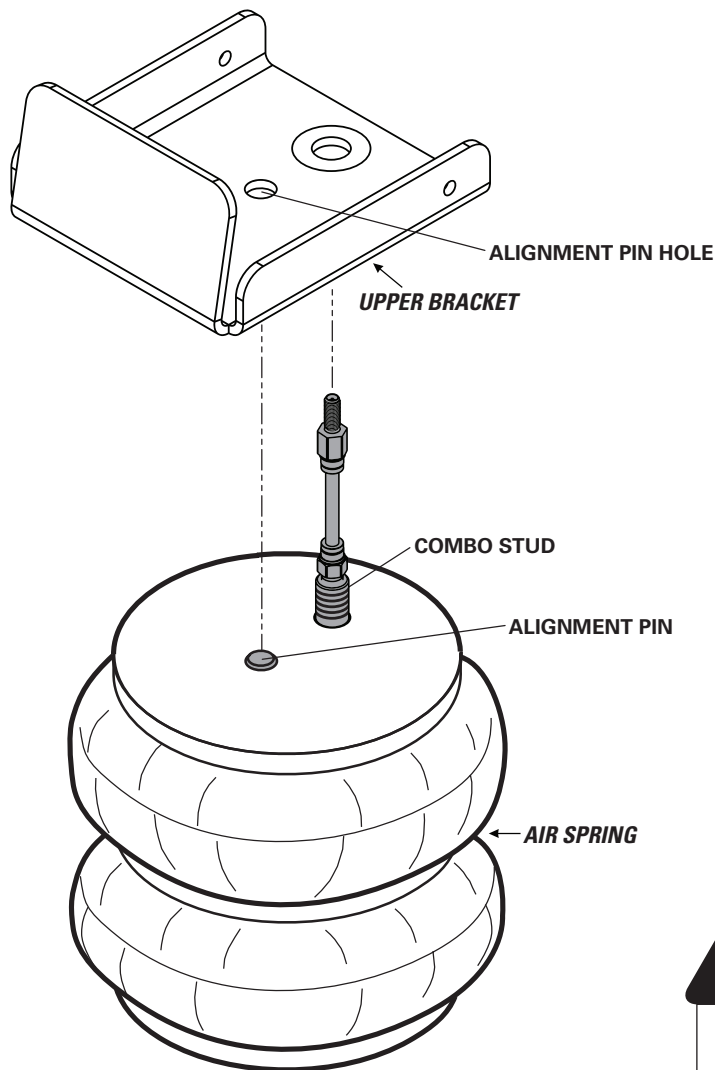

### RIGHT SIDE ONLY - INSTALL HEAD SHIELD

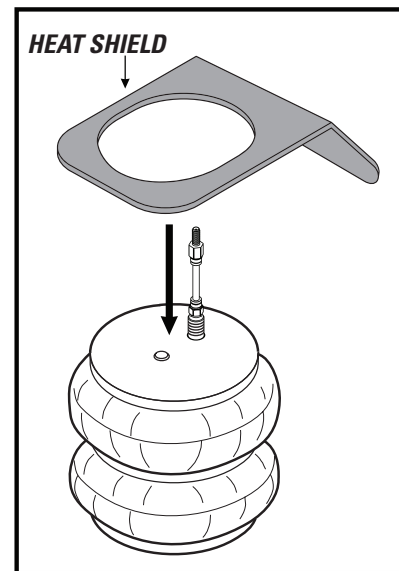

USE YOUR HAND TO CHECK FOR THE PROPER CLEARANCE AROUND THE AIR SPRING. IF YOUR HAND DOES NOT FIT BETWEEN THE AIR SPRING AND OTHER COMPONENTS, IT WILL RUB!



**1** Remove the air line tube from the air fitting on top of the air spring (see step 10-4 for removal instructions).

**2** Make sure that the alignment pin on top of the air spring has fully seated into the alignment pin hole in the upper bracket. It will “click” into place once seated correctly.

**3** Fully tighten the nut to the combo stud.

**VIEW ON VEHICLE**

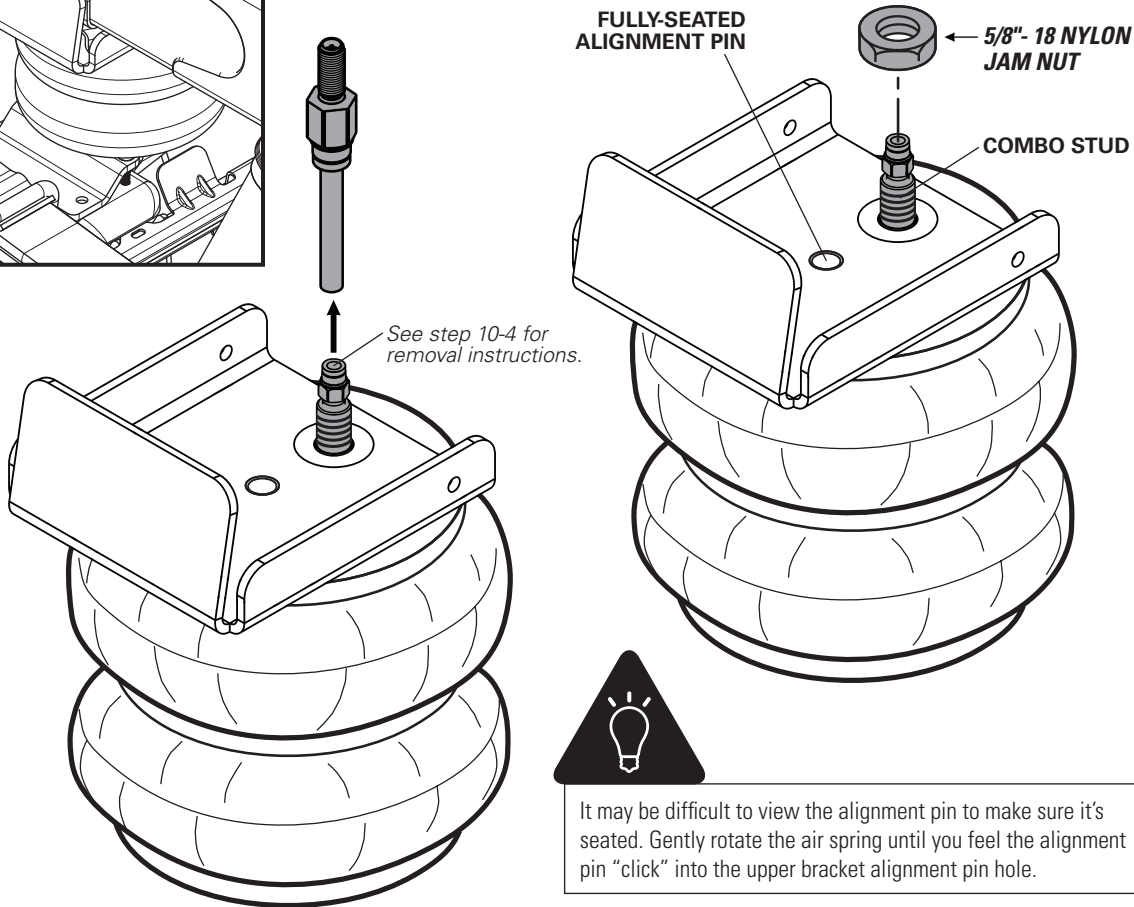
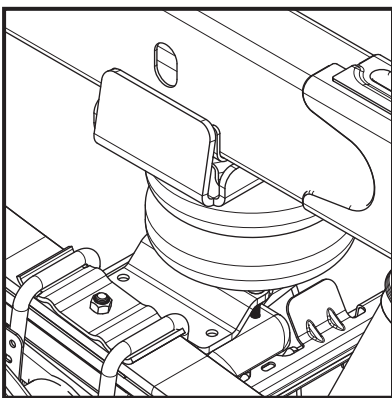

ALIGNMENT PIN ON AIR SPRINGS MUST BE INSTALLED TO FULLY SEAT INTO ONE OF THE ALIGNMENT HOLES IN THE UPPER BRACKET. FAILURE TO DO SO WILL CAUSE IT TO BE PUSHED INTO THE BEAD PLATE, CREATING AN AIR LEAK, AND RESULTING IN AN AIR SPRING FAILURE THAT IS **NOT WARRANTABLE. THE ALIGNMENT PIN CANNOT HOLD 2,500 LBS! IT IS USED FOR ALIGNMENT ONLY!**



It may be difficult to view the alignment pin to make sure it's seated. Gently rotate the air spring until you feel the alignment pin “click” into the upper bracket alignment pin hole.

# 8

## FASTEN THE AIR SPRING ASSEMBLY TO THE AXLE JOUCE BUMPER PAD

Most applications do not require the bracket strap and associated hardware. Use only if it assists in aligning the lower bracket to the axle jounce bumper pad. Review step 5 for correct alignment.

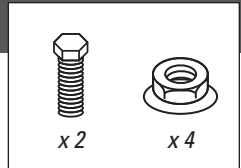

**1** Install the hex head screws into the two remaining outside holes in the axle jounce bumper pad, as shown.

**2** Attach the flange nuts to all four screws and tighten. Alternate tightening to draw lower bracket evenly to axle jounce bumper pad.

**3** Using an open-end wrench, fully tighten  $3/8"$  - 16 x .75" bolt on the bottom of the air spring.

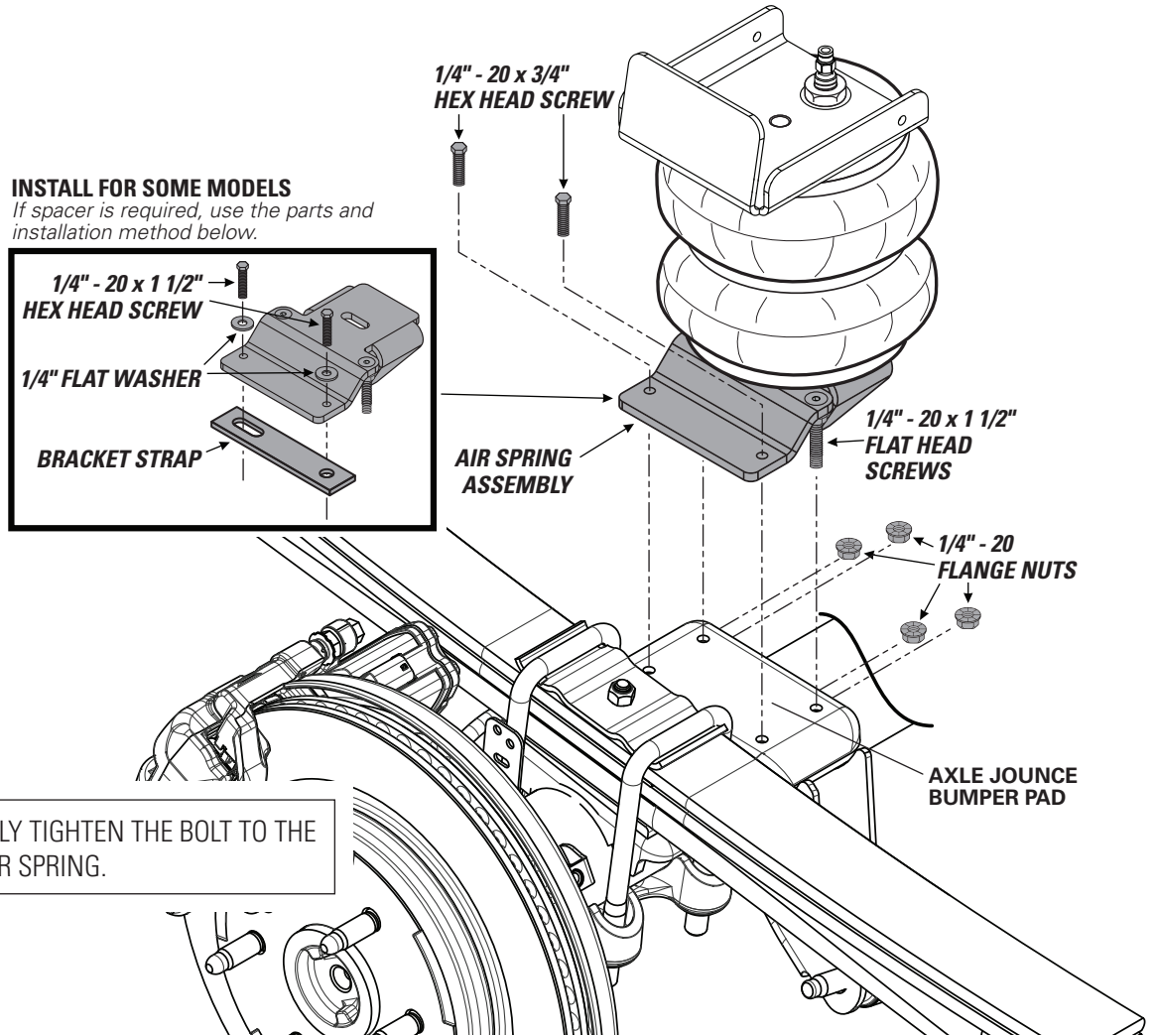

**INSTALL FOR SOME MODELS**  
If spacer is required, use the parts and installation method below.

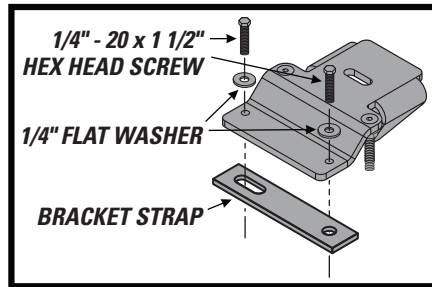

REMEMBER TO FULLY TIGHTEN THE BOLT TO THE BOTTOM OF THE AIR SPRING.



The factory rear brake line guard may be repositioned to gain better access to lower bracket fasteners. To perform this step, remove the three button-head fasteners using a T40 Torx bit. Gently release the plastic retainers on the guard from the brake line and carefully reposition it as needed for access to the bracket fasteners. Once the bracket fasteners are tightened (in this step), reposition the brake line guard, reinstall the Torx fasteners, and tighten them to the factory recommended torque specification.



**AWESOME!** You're done with the right side. Repeat steps 1-8 for the left side, then continue to step 9.

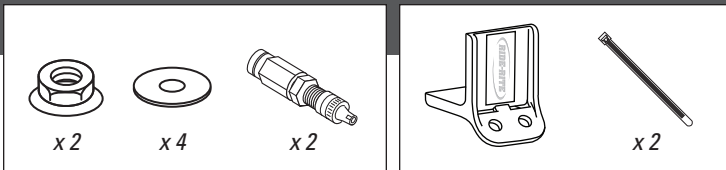

IF USING THE OPTIONAL NO-DRILL INFLATION VALVE BRACKET, CHOOSE OPTION 1. IF DRILLING, CHOOSE OPTION 2. **INFLATION VALVES MUST BE ACCESSIBLE BY AN AIR CHUCK.**

**1** Secure the air Inflation valve bracket to a protected, secure location. **PROCEED TO STEP 3.**

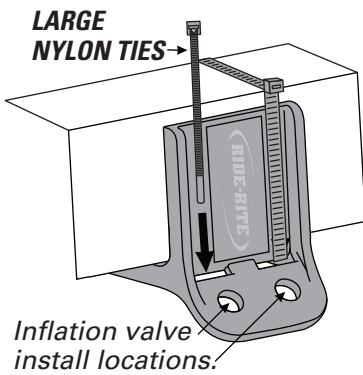

**2** Select a protected location to install the inflation valves, such as the bumper or the body of the vehicle.

Drill two 5/16" holes for inflation valve install locations.

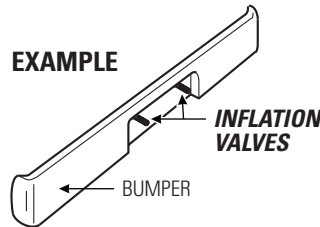

**3** Install inflation valve assembly as shown.

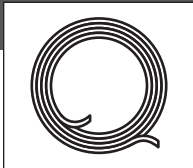
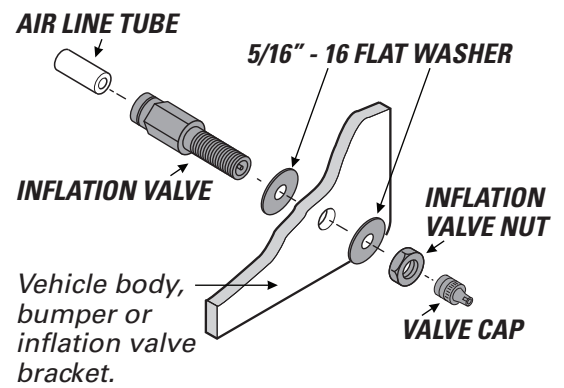

**1** Match air line tube ends.

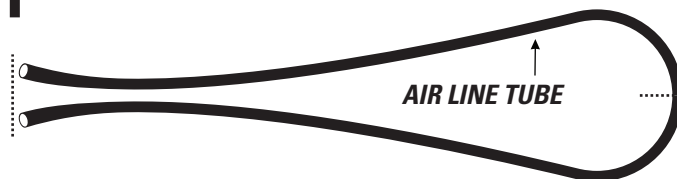

**2** Find center of air line tube, make a square cut with tube cutter or sharp utility knife.

**DO**

Make sure the cut is as square as possible. Use a tube cutter or sharp utility knife.

**DON'T**

Fold or kink the air line tube. Cut the air line tube at an angle. Use pliers, scissors, snips, saws, or side cutters.

**PROPER AND IMPROPER CUTS IN THE AIR LINE TUBE**

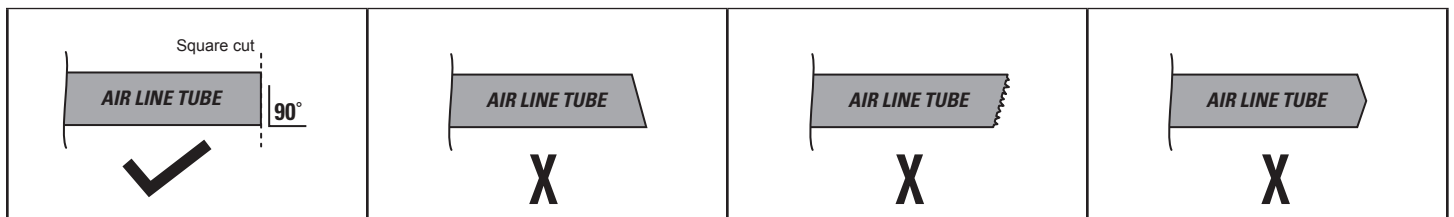

# 11

## INSTALLING AIR LINE TUBE INTO AIR FITTINGS AND INFLATION VALVE

**1** Insert end of air line tube into air fitting.

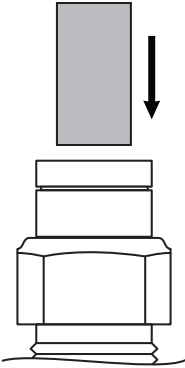

**2** Push air line tube into air fitting as far as possible.

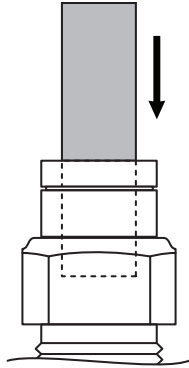

**3** Gently pull on the air line tube to check for a secure fit.

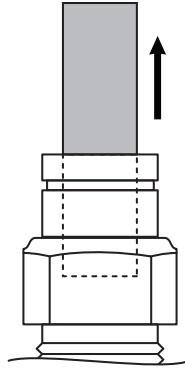

**4** To remove, push down collar and gently pull air line tube away.

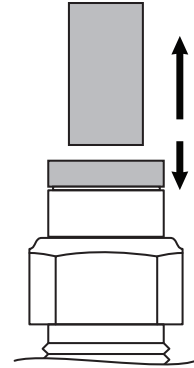

**Removal Tip:** Use a 1/4", 5/16", or 6mm open-ended wrench to push the collar down.

# 12

## ROUTE AND SECURE AIR LINE TUBES

Air line tube routes will vary, depending on your truck, and requires you to choose the best path from the air springs to the inflation valves. Use the instructions below to help you choose.

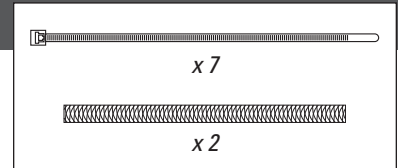

# DO

Select routes protected from heat, debris, and sharp edges. Use thermal shields near heat sources. Use Nylon ties to secure the air line tube.

# DON'T

Bend or sharply curve air line tubes. Leave air line tube exposed to sharp edges. Use unnecessary lengths of air line tube. Route air line tube near moving parts. Let air line tube hang unsecured from vehicle. Scar air line tube while routing.

**AIR LINE TUBE**      **THERMAL SHIELD**

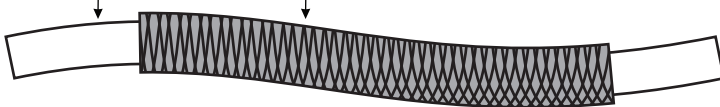

USE SUPPLIED THERMAL SHIELDS WHEN AIR LINE TUBE RUNS **WITHIN 6 INCHES** OF HEAT SOURCES.

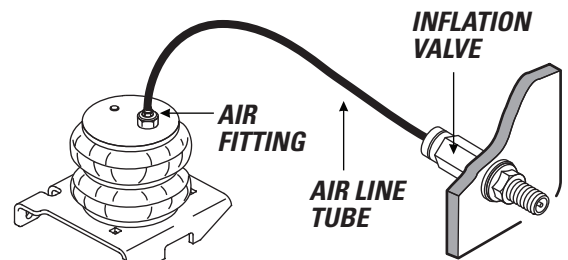

- 1** Place an air chuck onto the inflation valve and fill the system to **70 PSI**.

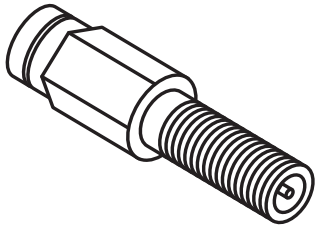

AIR SPRINGS INFLATE QUICKLY. CHECK AIR PRESSURE WHILE INFLATING.

- 2** Spray fittings with soap and water mixture.



- 3** Observe bubbles.

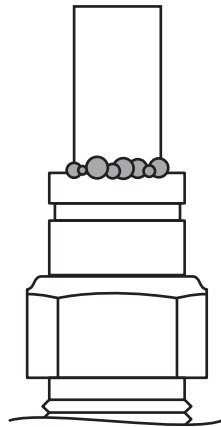

**SMALL SOAP BUBBLES  
THAT DO NOT EXPAND**

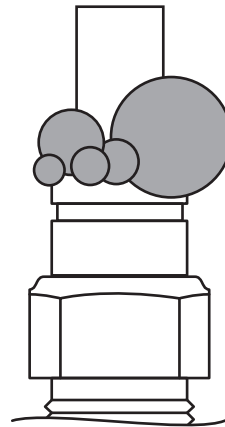

**SOAP BUBBLES  
THAT EXPAND**



# NO LEAKS?

Congratulations! Continue to step 15 to finish installation. Review the Operating Instructions.

# LEAK?

Bummer. Continue to step 14 to fix the leak.

# 14

## FIXING AN AIR LEAK

- 1 Press the air valve on end of inflation valve to release all air pressure.

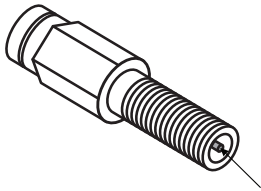

AIR VALVE



EXHAUST ALL AIR FROM THE SYSTEM PRIOR TO RELEASING AIR LINE TUBES FROM AIR FITTINGS.

### LEAK AT AIR LINE TUBE AND AIR FITTING

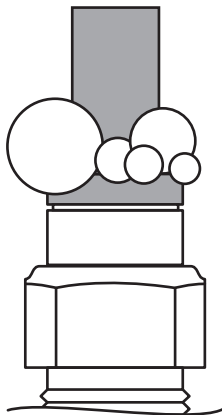

Release air line tube (see page 12). Review proper cuts and procedures in step 10. Repeat steps 11 and 13.

### LEAK AT BASE OF AIR FITTING ON AIR SPRING

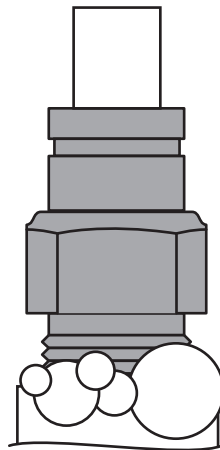

Tighten air fitting one turn or until leak stops.

### LEAK OUT OF THE VALVE CORE ON INFLATION VALVE

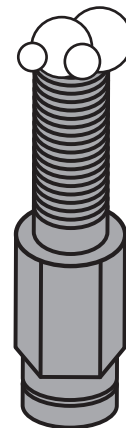

Tighten valve core with valve core wrench on inflation valve cap.

# STILL HAVE A LEAK?

Refer to the Troubleshooting section of the Instruction Manual. If the leak persists, or if there is an issue with a leaking part, call 1-800-888-0650; Option 1; Option 1 for Tech Support.

**SAFELY RETURN VEHICLE TO OPERATIVE STATE**

If you removed any wheels during installation, install the wheels and torque the lug nuts to the manufacturer's specifications.

Safely remove any jack stands and wheel chocks used during installation.

Re-attach the negative battery cable.

**DOUBLE-CHECK AIR SPRING CLEARANCE**

Check the air springs once again for the proper 1/2" minimum clearance. Perform clearance check again when vehicle is under load.

**VEHICLE GVWR**

NEVER exceed the maximum load recommended by the vehicle manufacturer (GVWR). The GVWR can be found in your vehicle's owner's manual or on the data plate on the driver's side door. Consult your local dealership for additional GVWR specifications.

**READ AND UNDERSTAND THE OPERATING INSTRUCTIONS**

The Ride-Rite system can improve handling and comfort. Take the time to learn how to properly use and maintain your investment by reading the Operating Instructions.



USE YOUR HAND TO CHECK FOR THE PROPER CLEARANCE AROUND THE AIR SPRING. IF YOUR HAND DOES NOT FIT BETWEEN THE AIR SPRING AND OTHER COMPONENTS, IT WILL RUB!

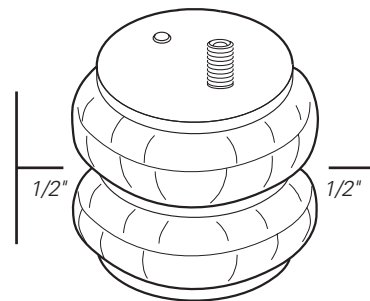

# ! IMPORTANT

**A MINIMUM OF 5 PSI MUST BE MAINTAINED IN THE AIR SPRINGS AT ALL TIMES**

Too much air pressure in the air springs will result in a firmer ride, while too little air pressure will allow the air springs to bottom out over rough conditions, and will not provide the improvement in handling that is possible.



MINIMUM PRESSURE



MAXIMUM PRESSURE (LOADED)





[riderite.com](http://riderite.com)

## BEFORE YOU DRIVE, CONFIRM THE FOLLOWING:

- Do you have a minimum of 5PSI in your air springs?
- Are your air springs standing 5 1/2" - 6 1/2" tall?
- Are your air springs properly aligned, left-to-right and front-to-back?
- Are your nuts and bolts tight?
- Put your paper work back into the sleeve and keep it in your glove compartment for future reference.
- You've been bagged...and now your suspension is Airide equipped! Show it off with the supplied decal!

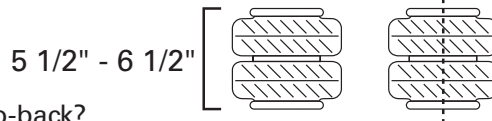

## NEED INSTALLATION HELP? 1-800-888-0650

Select Option 1 for Ride-Rite; Select Option 1 for Technical Support.

Or, email us at [rrtech@fsip.com](mailto:rrtech@fsip.com). Please include photos to help us better diagnose and understand any problems you may be experiencing.

# Firestone

Firestone Industrial Products

CONNECT WITH US



FirestoneIP



Firestone Ride-Rite



[riderite.com](http://riderite.com)

# INSTALLATION INSTRUCTIONS

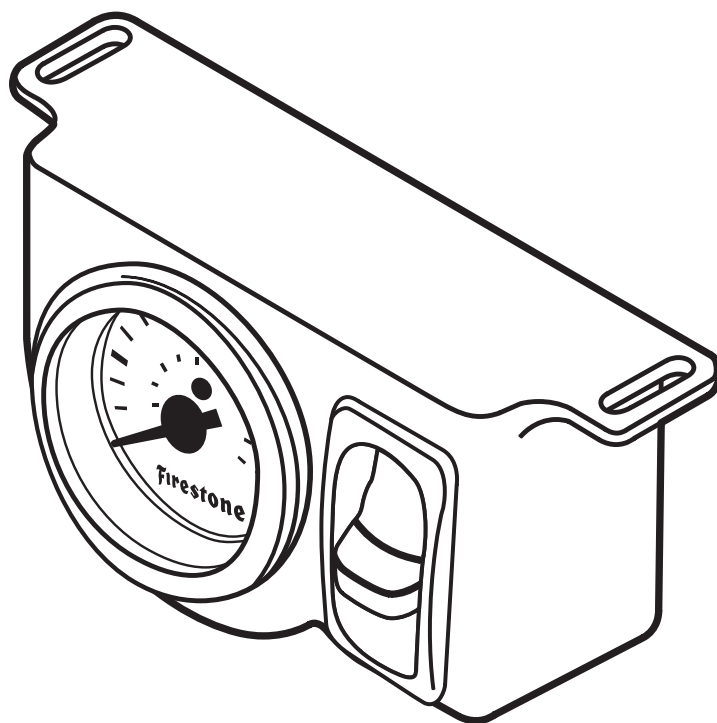

**Firestone**

Firestone Industrial Products

# ! IMPORTANT

*PLEASE DON'T HURT YOURSELF, YOUR KIT OR YOUR VEHICLE. TAKE A MINUTE TO READ THIS IMPORTANT INFORMATION.*

## **SAFE INSTALLATION**

Please take all safety precautions during installation. A hydraulic jack can fail, and if that happens, you can be seriously hurt, or worse, if you are relying on it to hold up the vehicle. If you use a hydraulic jack, secure jack stands in the appropriate locations and chock any tires still touching the ground.

Wear safety glasses or goggles. Your eyes may be lower than some parts and pieces, and you don't want to lose an eye.

Remove the possibility of any electrical issues by disconnecting the negative battery cable.

## **VEHICLE GVWR**

NEVER exceed the maximum load recommended by the vehicle manufacturer (GVWR). The GVWR can be found in your vehicle's owner's manual or on the data plate on the driver's side door. Consult your local dealership for additional GVWR specifications.

## **INFLATING THE AIR SPRINGS**

When inflating air springs, add air pressure in small quantities, checking air pressure frequently. The air springs have much less air volume than a tire, so they inflate much more quickly.

## **PRESSURE TO LOAD**

Be sure to review the load limits noted in the air spring kit installation instructions (sold separately).

## **APPROPRIATE AIR PRESSURE**

For best ride, use only enough air pressure in the air springs to level the vehicle when viewed from the side (front to rear). This will vary, depending on the load, location of the load, condition of the existing suspension, and personal preference.

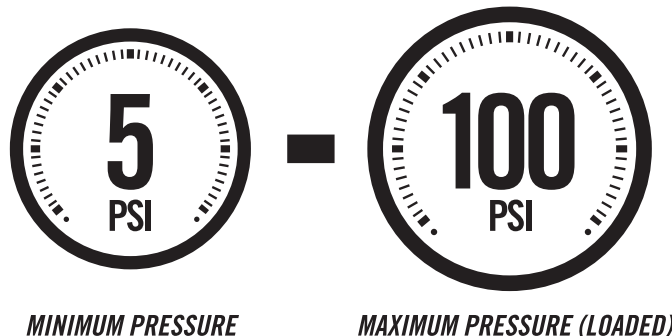

***ONCE INSTALLED SUCCESSFULLY, FOLLOW THESE PRESSURE REQUIREMENTS FOR THE AIR SPRINGS:***







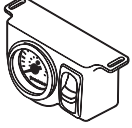
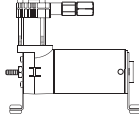
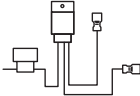



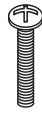

# PARTS

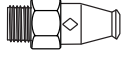
Compare the parts below to your kit. Assure you have all pieces, and organize them for an easier installation.

## MAIN KIT CONTENTS

PT # 2572	 x1 <i>SINGLE AIR CONTROL PANEL</i>	PT # 9523	 x1 <i>AIR COMPRESSOR</i>	PT # 9307	 x1 <i>RELAY HARNESS</i>
PT # 9416	 x1 <i>AIR LINE TUBE (30 FEET)</i>				

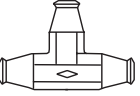
## A21-760-2158 HARDWARE PACK

PT # 3087	 x8 <i>10-32 x 1" MACHINE SCREW</i>	PT # 9078	 x1 <i>RED RING TERMINAL</i>	PT # 3055	 x1 <i>1/8 NPT PUSH-TO-CONNECT STRAIGHT FITTING</i>
PT # 3088	 x8 <i>10-32 LOCK NUT</i>	PT # 9083	 x2 <i>WIRE CONNECTOR</i>	PT # 9041	 x1 <i>LARGE RING TERMINAL</i>
PT # 3086	 x16 <i>#10 FLAT WASHER</i>	PT # 3025	 x1 <i>PUSH-TO-CONNECT T-FITTING</i>	PT # 9036	 x15 <i>NYLON TIE</i>
PT # 3025	 x1 <i>1/4" PUSH-TO-CONNECT TEE</i>	PT # 9041	 x1 <i>BLUE RING TERMINAL</i>		

# CONTENTS AND OVERVIEW

PAGE 4	PLANNING THE INSTALL
PAGE 5	PREPARE AIR COMPRESSOR & CONTROL PANEL
PAGE 6	DRILL HOLES FOR AIR COMPRESSOR INSTALLATION
PAGE 7	INSTALL THE AIR COMPRESSOR
PAGE 8	AIR COMPRESSOR TO CONTROL PANEL AIR LINE TUBE
PAGE 9	AIR SPRINGS TO CONTROL PANEL AIR LINE TUBE
PAGE 10	INSTALL RELAY HARNESS
PAGE 11	FINISH CONTROL PANEL WIRING & INSTALLATION
PAGE 12	INSTALL THE AIR FILTER & CLEAN UP INSTALLATION
PAGE 13	TEST THE SYSTEM
PAGE 14	FIXING AN AIR LEAK

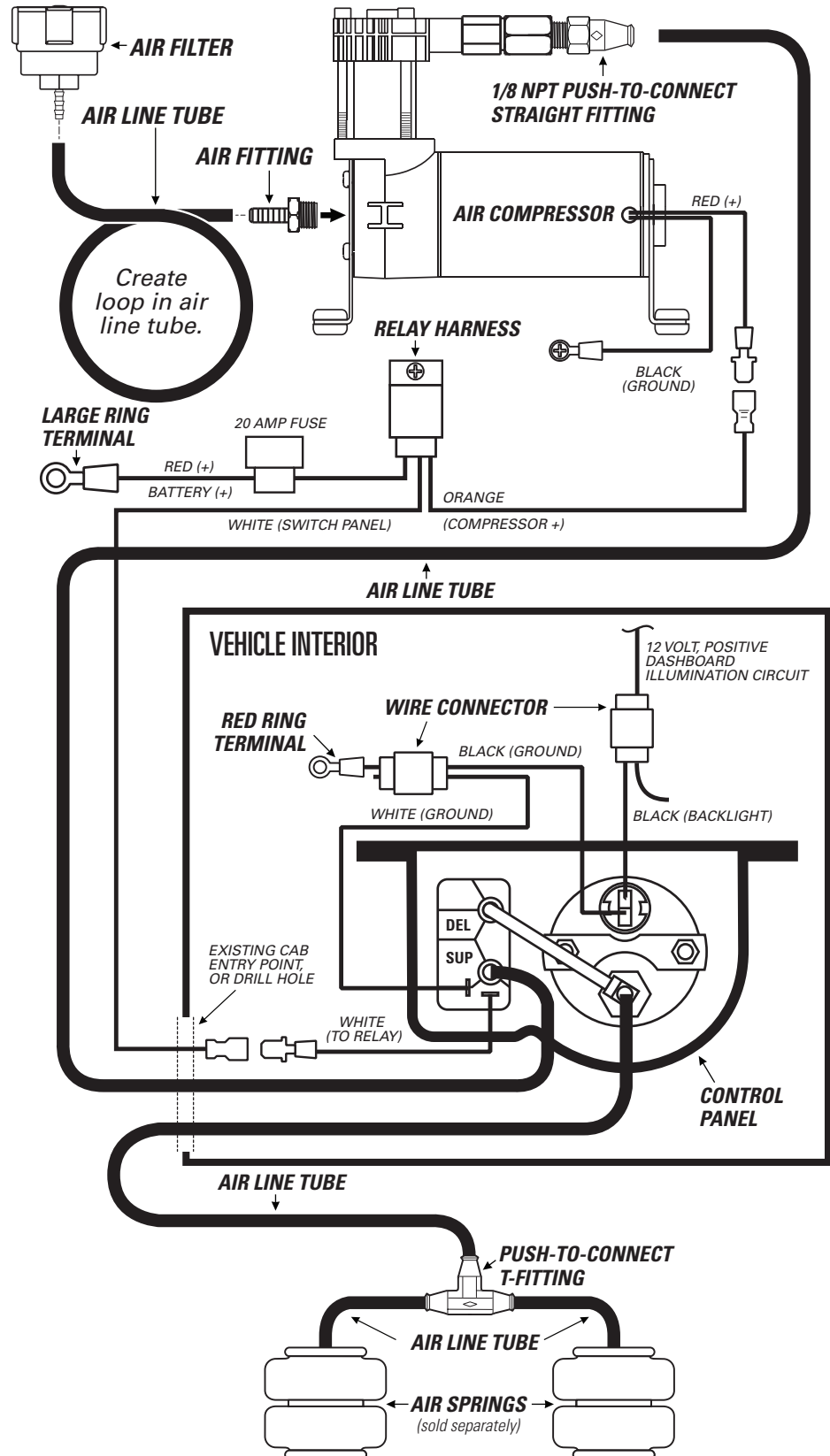

# PLANNING THE INSTALL

THESE PLANNING STEPS WILL HELP YOU SAVE TIME AND WILL MAKE THE INSTALLATION EASIER.

## **DETERMINE THE MOUNTING LOCATION FOR THE CONTROL PANEL**

- Mount inside the vehicle cab, in a place where you will not hit or kick it.
- Allow room for the air line tube to run without sharp curves or bends.
- Do not obstruct your view or ability to safely operate the vehicle.

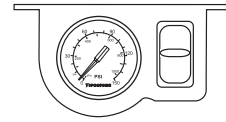

## **DETERMINE THE MOUNTING LOCATION FOR THE AIR COMPRESSOR**

- Provide ample air flow.
- Protect from airborne debris and moisture.
- If using the optional Frame Installation Kit (Part # 2497), consider the guidelines above, and follow kit's instructions.

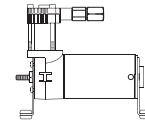

## **PLAN INSTALLATION ROUTES FOR WIRING AND AIR LINES INTO CAB**

- If possible, use existing factory grommet, such as where a wiring harness enters the cab.
- If not possible, drill a hole large enough for two air line tubes and a ground wire. Make sure the wiring and air line tubes are not exposed to sharp metal edges that can damage them.

## **SOAK AIR LINE TUBE ENDS IN HOT WATER BEFORE INSTALLING ONTO BARBED FITTINGS**

- The hot water makes the air line tube easier to work with and enables it to shrink onto the barbed fitting for a better seal.



## **TAPE ALL ELECTRICAL CONNECTIONS**

- Use electrical tape to appropriately secure and protect all electrical connections.

## **USING PUSH-TO-CONNECT FITTINGS FOR AIR LINES**

Your kit includes push-to-connect fittings to connect the air line tubes to hardware. Use the instructions below when using the air line.

- 1** Insert end of air line tube into air fitting.

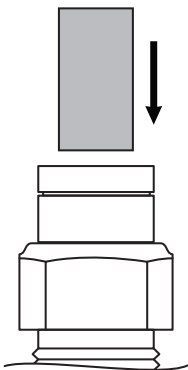

- 2** Push air line tube into air fitting as far as possible.

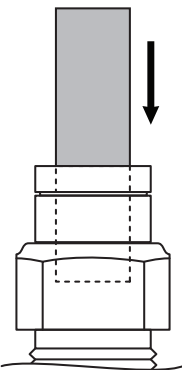

- 3** Gently pull on the air line tube to check for a secure fit.

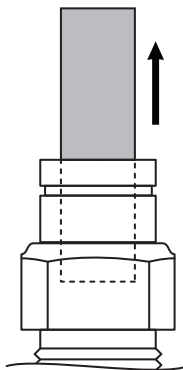

- 4** To remove, push down collar and gently pull air line tube away.

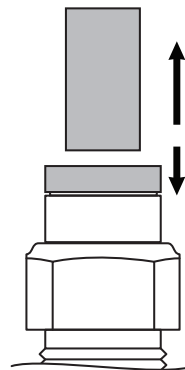

**Removal Tip:** Use a 1/4", 5/16", or 6mm open-ended wrench to push the collar down.

# 1

## PREPARE THE AIR COMPRESSOR

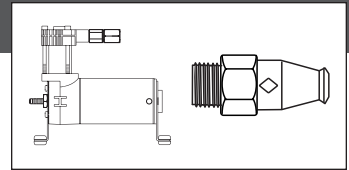

- 1 Install 1/8 NPT push-to-connect straight fitting to the head of the air compressor.

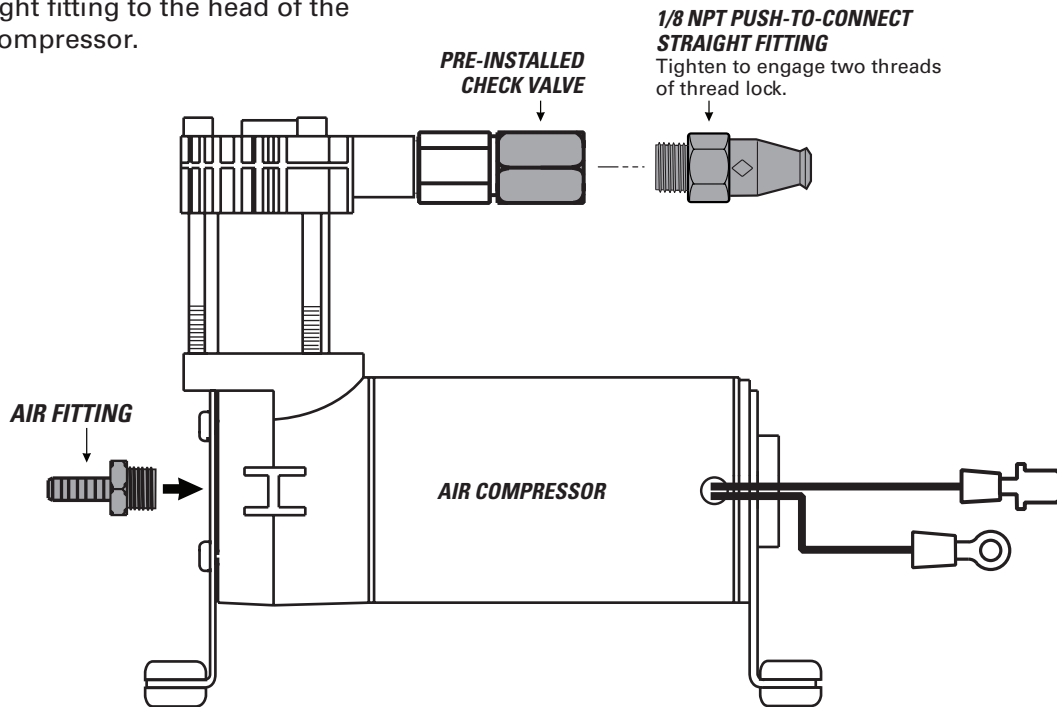

# 2

## DRILL HOLES FOR CONTROL PANEL INSTALLATION

Use the location you selected during the Planning the Installation step on page 4.

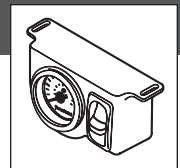

- 1 Using the control panel slots as a template, mark two drill locations with a punch or marking tool.

- 2 Drill a 3/16" diameter hole on each center mark.

- 3 Do not mount the control panel until step 8.

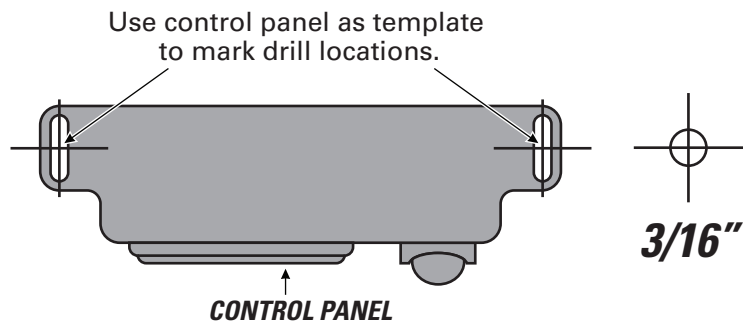

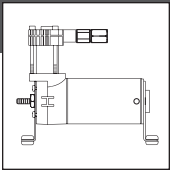

IF YOU ARE USING THE OPTIONAL FIRESTONE AIR COMPRESSOR MOUNTING KIT (PART # 2497), SKIP THIS STEP AND REFER TO THE MOUNTING KIT'S INSTRUCTIONS.



CHECK SURROUNDING AREA AND BACK SIDE OF MOUNTING LOCATION TO AVOID DRILLING INTO EXISTING LINES OR WIRING.

**1** Using the air compressor as a template, mark four drill locations with a punch or marking tool.

**2** Mark ground wire fastening location within reach of the ground wire ring terminal.

**3** Drill 3/16" diameter holes. Remove any burrs and debris from drill holes.

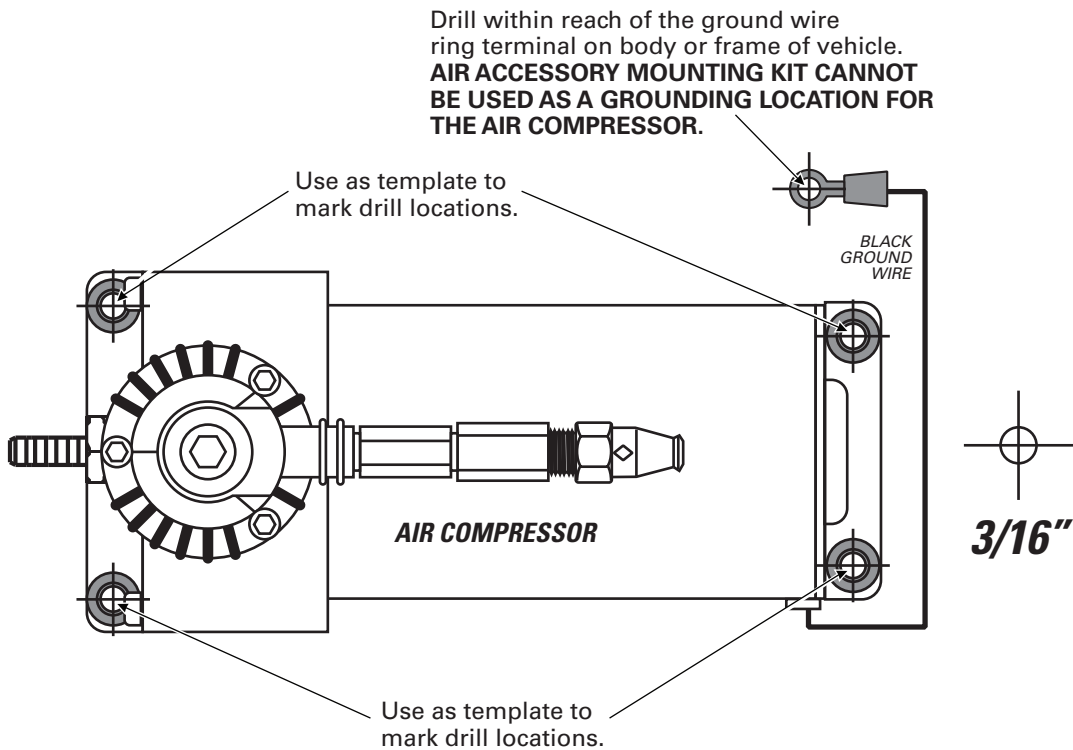



# 4

## INSTALL AIR COMPRESSOR

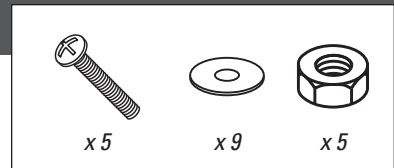

DO NOT OVER TIGHTEN MOUNTING BOLTS AND NUTS. TOO MUCH TORQUE CAN CRUSH THE BRASS INSERTS AND RUBBER ISOLATORS.

**1** Mount the air compressor to the drill hole location using the supplied fasteners. DO NOT OVERTIGHTEN.

**2** Mount the black ground wire ring terminal using the supplied fasteners. Assure that the ring terminal makes a solid contact with bare metal for a proper ground. (Optionally, you can run the negative to the negative battery terminal.)

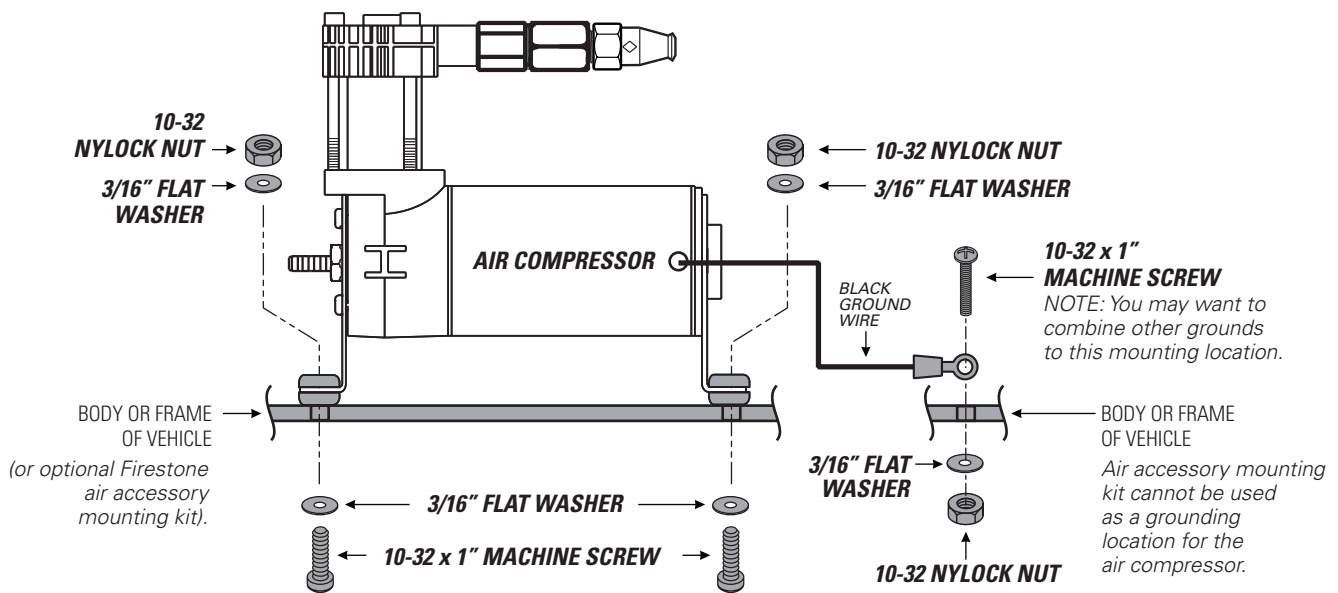

TO CREATE A PROPER GROUND, ASSURE THE GROUND RING TERMINAL CONTACTS BARE METAL AND IS FASTENED SECURELY. AFTER INSTALLATION, YOU MAY OPTIONALLY COAT THE RING TERMINAL IN SILICONE TO PROTECT IT FROM CORRODING.



Use the route you selected during the Planning the Installation step on page 4.

**1** Route the air line tube from the air compressor to the control panel, leaving room to secure line safely. Use guidelines below to cut.



EXHAUST ALL AIR FROM THE SYSTEM PRIOR TO RELEASING AIR TUBES FROM AIR FITTINGS.



**2** Install the air line tube end onto the barbed fitting on the back of the control panel switch as shown.



FOR PROPER INSTALLATION, SOAK AIR LINE TUBE ENDS IN HOT WATER BEFORE INSTALLING ONTO BARBED FITTINGS.

**3** Install the air line tube end into the 1/8 NPT push-to-connect straight fitting on the top of the air compressor.

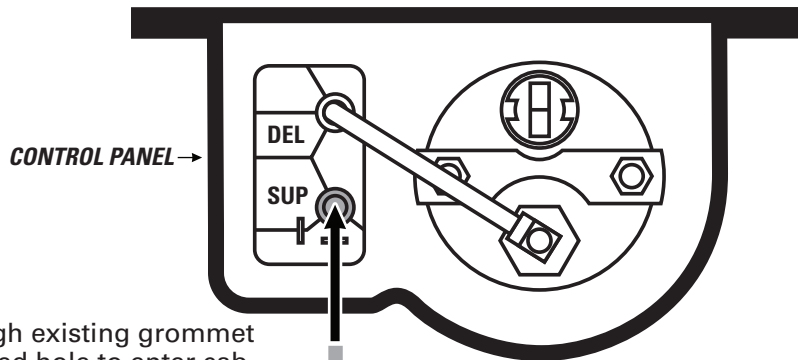

Pass through existing grommet or drilled hole to enter cab.

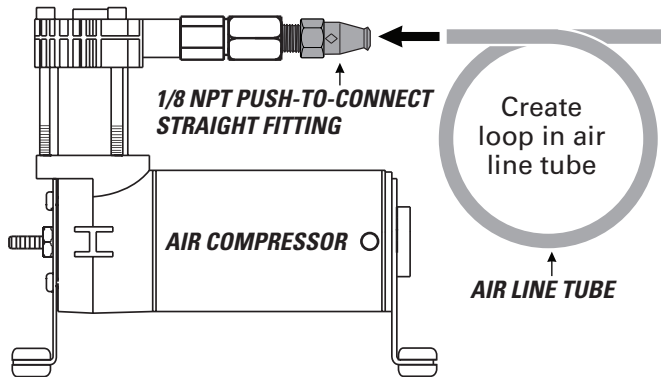

THE AIR LOOP CREATES A TRAP FOR CONDENSATION TO GATHER. WITHOUT THIS TRAP, THE AIR COMPRESSOR COULD BE DAMAGED BY WATER INTAKE.

**DO**

Make sure the cut is as square as possible. Use a tube cutter or sharp utility knife.

**DON'T**

Fold or kink the air line tube. Cut the air line tube at an angle. Use pliers, scissors, snips, saws, or side cutters.

**PROPER AND IMPROPER CUTS IN THE AIR LINE TUBE**

<p>Square cut AIR LINE TUBE 90°</p>	<p>AIR LINE TUBE</p>	<p>AIR LINE TUBE</p>	<p>AIR LINE TUBE</p>
---	----------------------	----------------------	----------------------

# 6

## INSTALL T-FITTING AND ROUTE AIR LINE TUBE TO CONTROL PANEL

Use the route you selected during the Planning the Installation step on page 4.

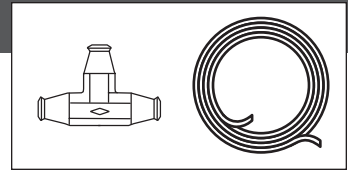

EXHAUST ALL AIR FROM THE SYSTEM PRIOR TO RELEASING AIR TUBES FROM AIR FITTINGS.



FOR PROPER INSTALLATION, SOAK AIR LINE TUBE ENDS IN HOT WATER BEFORE INSTALLING ONTO BARBED FITTINGS.

**1** Route the air line tube from the control panel to the air springs.

**2** Install the air line tube end onto the barbed fitting on the back of the control panel pressure gauge as shown.

**3** Determine a safe location for the push-to-connect T-fitting, where air line tubes from the air springs and the control panel can safely meet.

**4** Install the air line tubes from the air springs into opposite ends on the push-to-connect T-fitting, as shown.

**5** Install the air line tube from the control panel to the single end on the push-to-connect T-fitting.

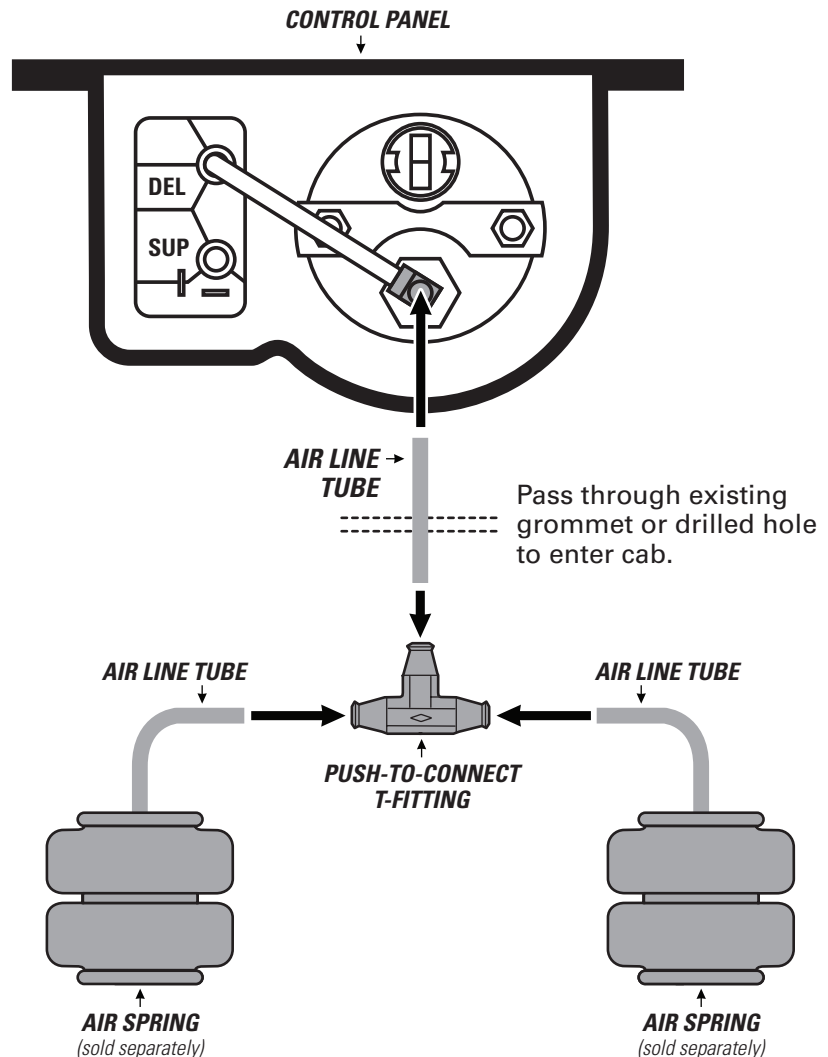

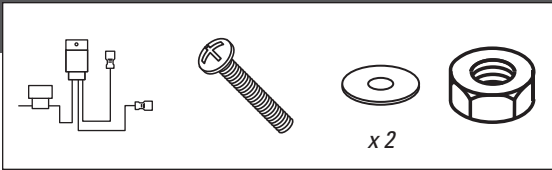

**1** Select a safe location within 3 feet of the air compressor.

**2** Mark and drill a 3/16" hole to mount the relay housing on the relay harness. Secure with fasteners shown.

**3** Route the white wire with the female spade connector labeled "switch panel" to the control panel.

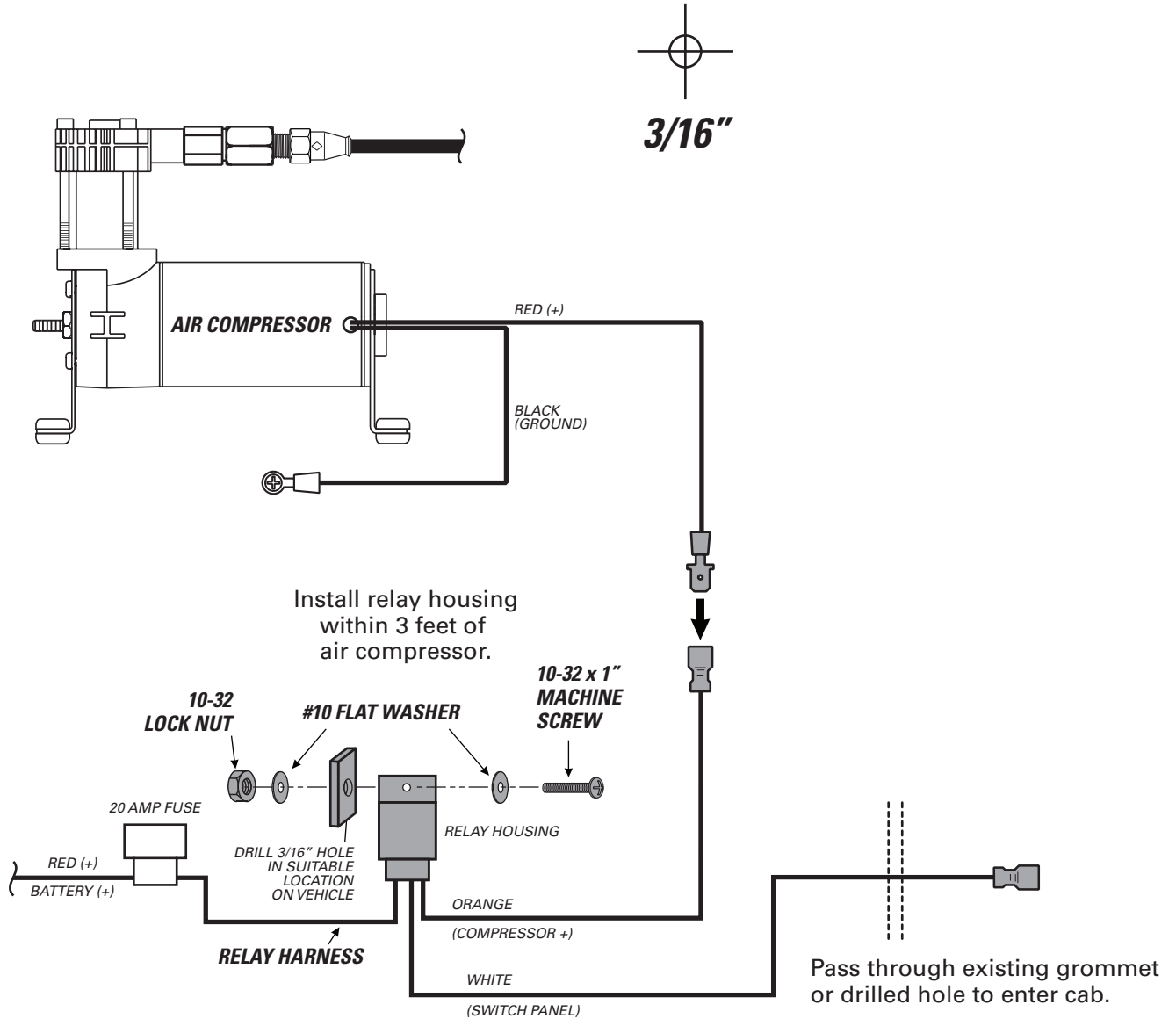

# 8

## FINISH WIRING AND INSTALLATION



x 2



x 3



x 6



x 3

**1** Connect wires, install ring terminals and wire connectors as shown below.

**2** Fasten control panel ground wires to vehicle as shown.

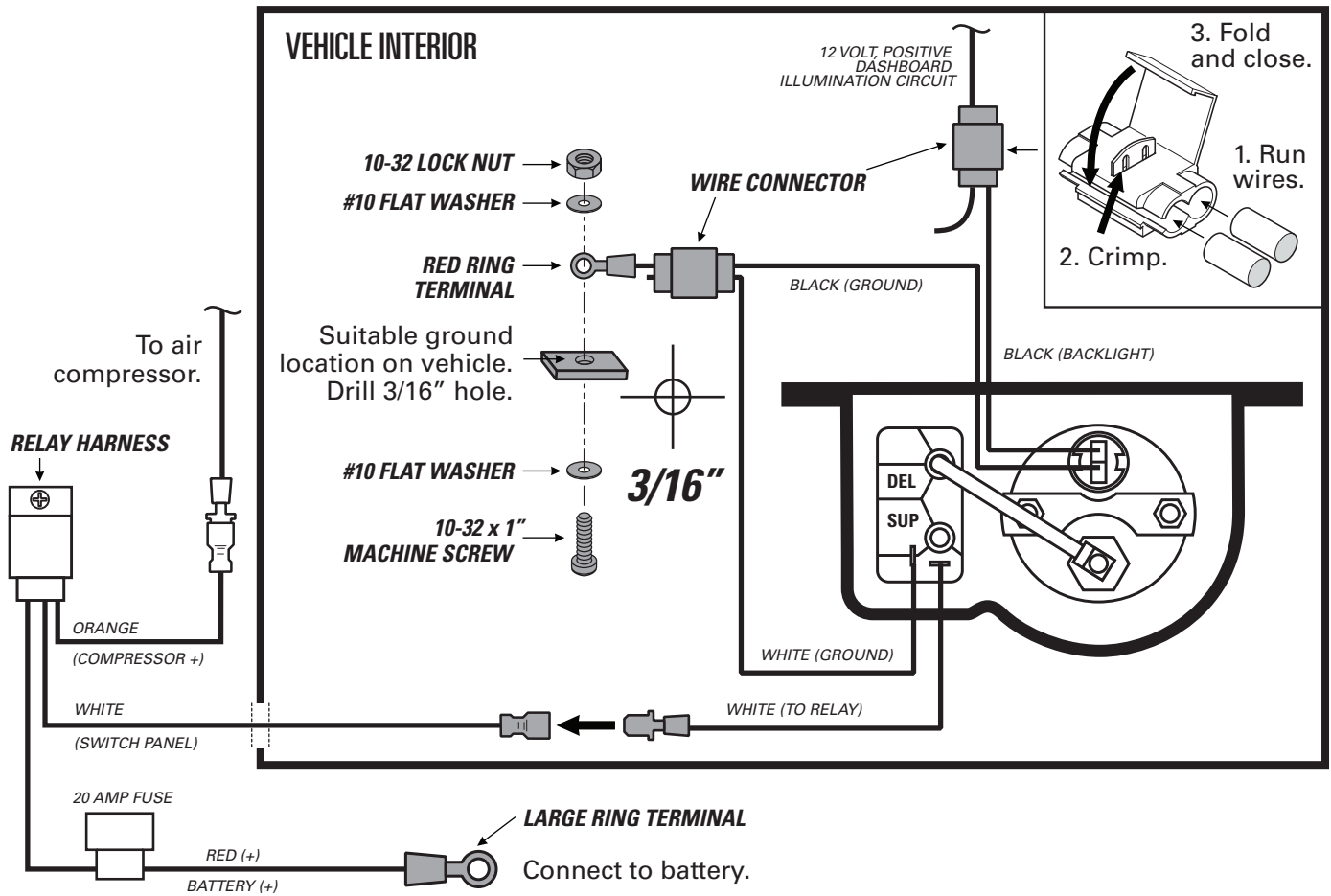

**3** Install the control panel using the supplied fasteners.

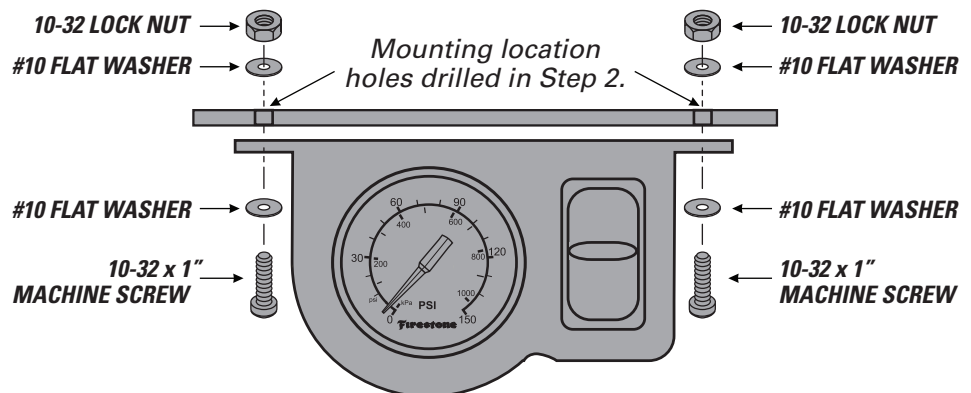

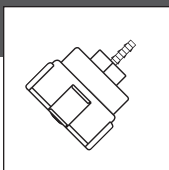

FILTER LIFE WILL VARY BASED ON ENVIRONMENTAL CONDITIONS. PROTECT THE AIR COMPRESSOR BY CHANGING THE AIR FILTER MORE FREQUENTLY IN DUSTY CONDITIONS.

- 1** Fully secure the air filter barb into the air line tube from the air compressor kit.
- 2** Press air line tube onto the barb on the air compressor air fitting until fully seated. Assure you create a loop in the air line tube, as shown, when securing it to the vehicle.
- 3** Periodically check the air filter during operation. When the air filter is dirty and needs to be replaced, contact an Authorized Firestone dealer to purchase a new one.

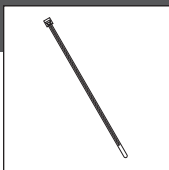
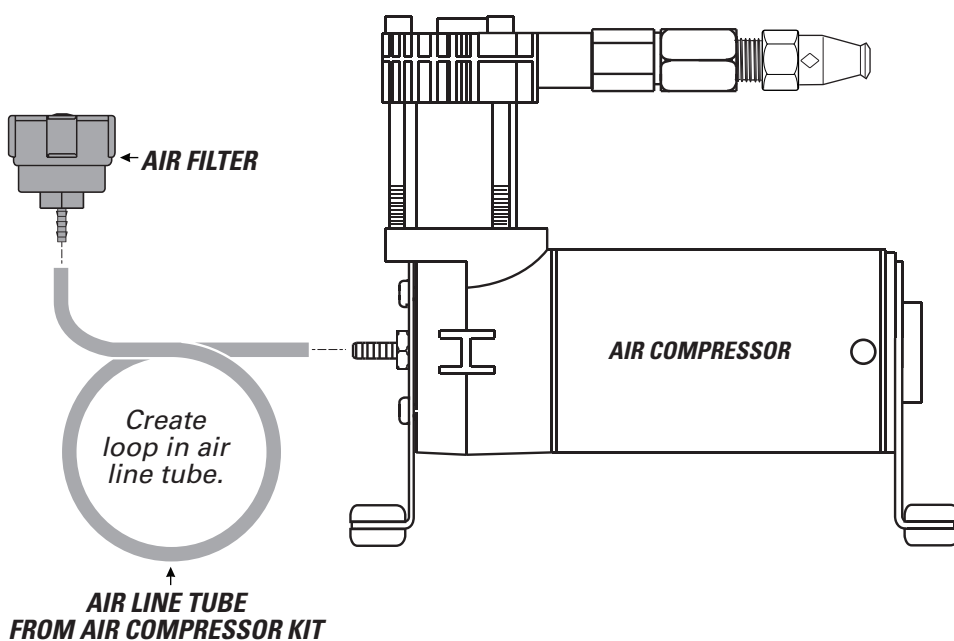

- 1** Clean up the installation using supplied Nylon ties, and return all factory parts and materials to operative state.



USING SUPPLIED NYLON TIES, SECURE ALL WIRING AND AIR LINE TUBE IN A MANNER THAT DOES NOT OBSTRUCT YOUR VIEW OR ABILITY TO SAFELY OPERATE THE VEHICLE.

# 10

## TEST THE SYSTEM

With the Air Command™ kit and your air springs installed, you are ready to test the system.

- 1** Re-attach the negative battery cable.

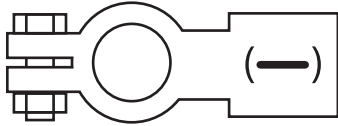

- 2** Turn on your vehicle's ignition.

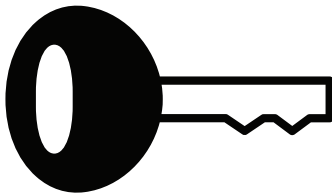

- 3** Push paddle switch up to inflate the air springs to 70 PSI.

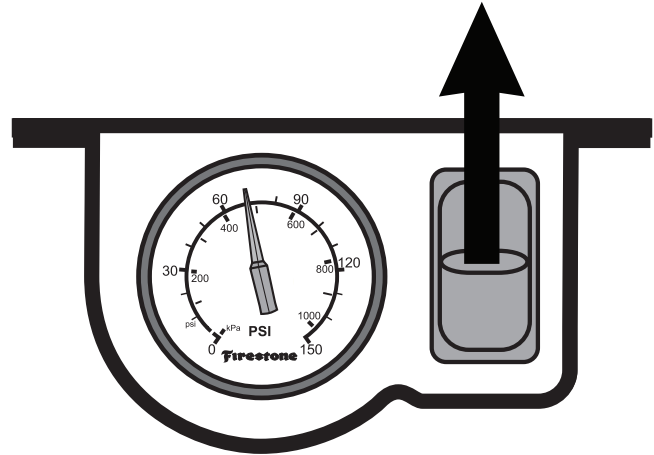

- 4** Spray fittings with soap and water mixture.



- 5** Observe bubbles.

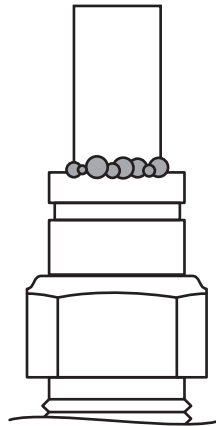

**SMALL SOAP BUBBLES  
THAT DO NOT EXPAND**

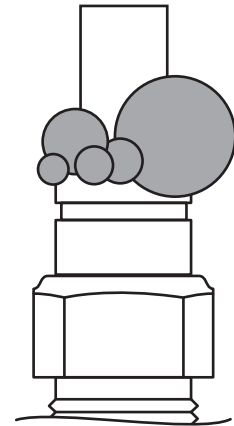

**SOAP BUBBLES  
THAT EXPAND**



# NO LEAKS?

Congratulations! You're riding right with the flip of a switch! Remember to review the Operating Instructions.

# LEAK?

Bummer. Continue to step 11 to fix the leak.



EXHAUST ALL AIR FROM THE SYSTEM PRIOR TO RELEASING AIR TUBES FROM AIR FITTINGS.



- 1** Push paddle switch down to release all air pressure from the air springs.

NOTE: While doing this, if you get a quick burst of air prior to the gauge dropping to 0 PSI, your lines are incorrectly swapped.

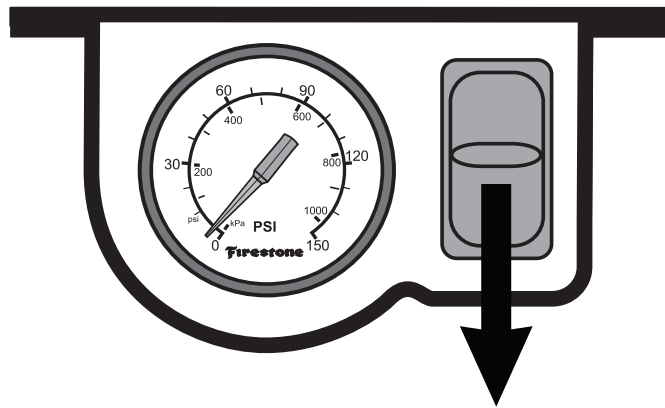

#### LEAK AT AIR LINE TUBE AND AIR FITTING

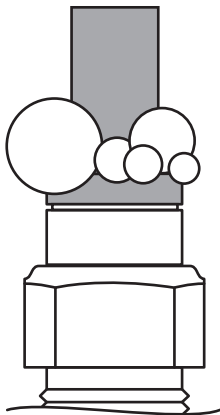

Release air line tube (see page 4). Review proper cuts and procedures in step 5. Repeat installation steps.

#### LEAK AT BASE OF AIR FITTING ON AIR SPRING

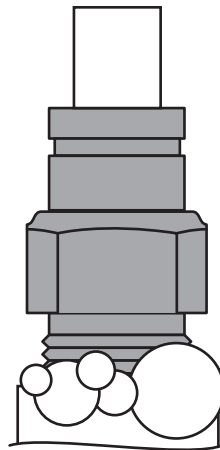

Tighten air fitting one turn or until leak stops.

#### LEAK AT A BARBED FITTING

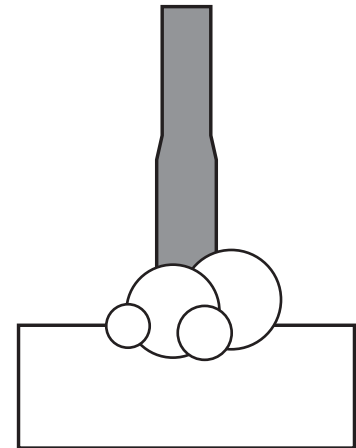

Being careful not to scar the metal barbs, cut away, check for debris. Trim air tube line, **soak for 5 minutes in hot water**. Reinstall.

## STILL HAVE A LEAK?

Refer to the Troubleshooting section of the Instruction Manual. If the leak persists, or if there is an issue with a leaking part, call 1-800-888-0650; Option 1; Option 1 for Tech Support.





[riderite.com](http://riderite.com)

## BEFORE YOU DRIVE, CONFIRM THE FOLLOWING:

- Secure all air line tubes and wiring inside the cab and on the outside of the truck.
- Make sure no wiring, air line tubes, or hardware obstruct your vision or ability to safely operate the vehicle.
- The system passes the leak test and holds air.
- The air compressor ground ring terminal is contacting bare metal, and coated with silicone if possible.
- There is a loop in the air line tubes as shown to prevent water or debris from getting into the air compressor head and damaging it.
- The air gauge backlight turns off when the ignition is off, or when dashboard lights do not illuminate.
- Put a minimum of 5 PSI in the air springs, unloaded.

## NEED INSTALLATION HELP? 1-800-888-0650

Select Option 1 for Ride-Rite; Select Option 1 for Technical Support.

Or, email us at [rrtech@fsip.com](mailto:rrtech@fsip.com). Please include photos to help us better diagnose and understand any problems you may be experiencing.

# Firestone

Firestone Industrial Products

CONNECT WITH US



FirestoneIP



Firestone Ride-Rite



# Do Not Return This Product to the Dealer or Distributor

## If you are

- missing parts,
- experiencing installation problems, or
- have technical concerns regarding this product,

you may contact a Firestone Technical Service Representative at [rrtech@fsip.com](mailto:rrtech@fsip.com) or at 800-888-0650 (option 1, and then option 2). Representatives are available from 7:30 a.m. – 4:30 p.m. Eastern on Monday – Friday, excluding holidays. If you are located outside of the United States, you should first contact your distributor or dealer directly with any issues.

When contacting Technical Service, please have the kit or part # ready, along with the make, model, and year of the vehicle. You may also need to provide details, such as 2WD/4WD or if the vehicle has been lifted or lowered from stock height.

If you have a warranty concern, please include in your email a detailed description of the situation, a photo(s) of the issue, and your contact information, including ship-to address.

**WARRANTY COVERAGE\***— The Ride-Rite™ kits, components, and accessories are warranted against defects in workmanship and materials. This warranty does not cover service or labor charges, neglect...to the product.

### **PERIOD OF COVERAGE:**

- |   |  |
|---|--|
| • Ride-Rite air springs – Lifetime Limited  | • Work-Rite load assists – 2 Years Limited                                       |
| • Sport-Rite air springs – Lifetime Limited | • Air-Rite accessories – 2 Years Limited   |
| • Coil-Rite air springs – Lifetime Limited  | • Brackets, hardware, fittings, air line, and other components – 2 Years Limited |
| • Level-Rite air springs – Lifetime Limited |  |

**HOW TO MAKE A WARRANTY CLAIM** — If you purchased your air springs in the U.S. or Canada and believe you have a part with a warrantable defect, call Firestone directly at 1-800-888-0650.

International customers should contact their distributors or dealers directly with any problems.

(\*) Please refer to the “Firestone Limited Lifetime Air Spring Warranty” for details, terms, and conditions.

## **WARRANTY QUESTIONS**

Go to [www.riderite.com/installation-support](http://www.riderite.com/installation-support)  
Select “Warranty Info” tab