



FITTING INSTRUCTIONS

LAND ROVER DISCOVERY

No 32/3432050

**DELUXE AND WINCH BULL BARS
(JANUARY 1995 ONWARD)**

WARNING

**FOR VEHICLES EQUIPPED WITH SRS AIRBAG
WHEN INSTALLED IN ACCORDANCE WITH THESE INSTRUCTIONS, THE FRONT
PROTECTION BAR DOES NOT AFFECT OPERATION OF THE SRS AIRBAG.**

TAKE NOTE OF THE FOLLOWING:

- **THIS PRODUCT MUST BE INSTALLED EXACTLY AS PER THESE INSTRUCTIONS USING ONLY THE HARDWARE SUPPLIED.**
- **DO NOT USE THIS PRODUCT FOR ANY VEHICLE MAKE OR MODEL, OTHER THAN THOSE SPECIFIED BY ARB.**
- **DO NOT REMOVE LABELS FROM THIS BULL BAR.**
- **THIS PRODUCT OR ITS FIXING MUST NOT BE MODIFIED IN ANY WAY.**

FITTING KIT (TO SUIT BOTH BULL BARS) No. 6171239

PART No	QTY	DESCRIPTION	USE	
3500080	1	INDICATOR KIT (contains L and R)	TURN SIGNAL INDICATORS	
6151017	2	M6 X 16mm BOLT	NUMBER PLATE TO BULL BAR	
6151046	2	M6 FLAT WASHER		
6151128	2	M6 FLANGE NUT		
3500200	1	BUFFER KIT		RUBBER BUFFER TO BULL BAR
3751627L	1	IMPACT ABSORBER (LHS)	IMPACT ABSORBERS AND MOUNT ASSEMBLY TO CHASSIS	
3751627R	1	IMPACT ABSORBER (RHS)		
5846273	2	CHASSIS PACKER INSIDE		
5846274	2	CHASSIS PACKER OUTSIDE		
6151105	4	1/2" X 4 1/2" BOLT		
6151106	2	1/2" X 5" BOLT		
4581007	2	40mm HEAVY DUTY WASHER		
4581050	6	1/2" SPRING WASHER		
4581049	10	1/2" FLAT WASHER		
6151138	6	1/2" NUT		
180302	1	CABLE TIE		
6151087	8	M10 X 25mm BOLT		BULL BAR TO IMPACT ABSORBER
4581048	8	M10 SPRING WASHER		
4581039	16	M10 FLAT WASHER		
6151033	8	M10 X 1.25 NUT		

ADDITIONAL FITTING KIT FOR THE WINCH BULL BAR No. 6171223

PART No	QTY	DESCRIPTION	USE	
6151118	2	1/4" NUT	CONTROL BOX TO CONTROL BOX BRACKET: (A) For 8 or 9,000lb winch	
4581035	2	M6 FLAT WASHER		
4581036	2	M6 SPRING WASHER		
6151118	4	1/4" NUT	CONTROL BOX TO CONTROL BOX BRACKET: (B) For 10,000lb winch	
6151068	2	1/4" X 1" BOLT		
4581036	4	M6 SPRING WASHER		
3756499	1	CONTROL BOX BRACKET UNIV	CONTROL BOX BRACKET TO BULL BAR	
6151234	2	M8 X 25mm BOLT		
4581045	2	M8 FLAT WASHER		
4581047	2	WASHER SPRING M8		
6151132	2	M8 FLANGE NUT		
EG50	2	RUBBER GROMMET		
BLR850	1	WIRING LOOM RED		CABLES 10,000lb WINCH ONLY (supplied with winch guard)
BLB850	2	WIRING LOOM BLACK		
6151094	2	M12 X 30 mm BOLT	ROLLER FAIRLEAD TO BULL BAR	
4581050	2	1/2" WASHER SPRING		
4581049	4	1/2" WASHER FLAT		
6151135	2	M12 X 1.25 NUT		
4601021	1	WINCH MOUNT CRADLE	WINCH MOUNT CRADLE TO CHASSIS	
4581040	4	3/8" FLAT WASHER	WINCH 8 OR 9,000lb ONLY	
4581042	4	7/16" WASHER FLAT	WINCH 10,000lb ONLY	
3532030	1	WINCH GUARD M8/9	WINCH 8 OR 9000LB	

TOOLS REQUIRED

Basic tool kit, level, tape measure, drill and 1/2" drill bit.

FITTING PROCEDURE

1. Disconnect the headlight washers at the T piece by cutting the tube, take care as the T piece is fragile.

NOTE: First temporarily block the tube to prevent loss of washer fluid.

2. Remove the bumper bar.

3. Remove the headlight washers and tubing from the bumper bar and fit to the bull bar. Make sure the tubing is fed through the holes in the bull bar upright.

4. Fit the turn signal indicators supplied into the bull bar. NOTE: Refer to the instructions supplied with the turn signal indicator kit.

5. WINCH BARS: FITTING THE 8 OR 9,000lb WINCH

A. Fit winch control box bracket (3756499) to control box studs as shown in Fig A.

B. Using M8 fasteners fit control box mounting bracket to pan, see Fig B .



Fig A



Fig B

- B. To place the winch clutch handle in a convenient location, the winch gearbox must be rotated 2 hole spacings, 72 degrees, in a clockwise direction when viewed from the gearbox end. Place the winch on its end and remove all gearbox bolts. Gently raise the gearbox just enough to rotate it. Do not completely remove the gearbox and avoid damaging the gasket. Refit all bolts and tighten.

DIAGRAM 2A

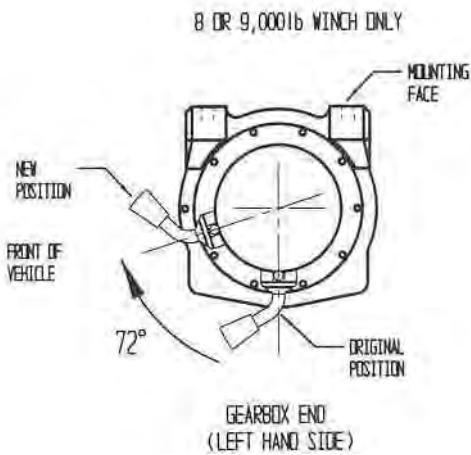

DIAGRAM 2B

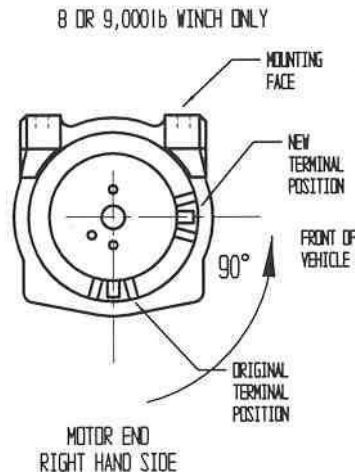
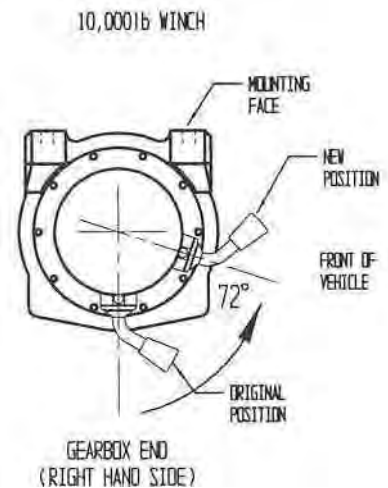

DIAGRAM 2C



- C. To place the winch motor in the correct location, the winch motor must be rotated 90 degrees, in an anti-clockwise direction when viewed from the motor end. Place the winch on its end and remove the 2 motor retaining bolts. Gently raise the motor just enough to rotate it. Do not completely remove the motor and avoid damaging the gasket. Refit all bolts and tighten. Refer to diagram 2B.
- D. Fit the roller fairlead into the front of the bull bar using the M12 x 30mm bolts, flat washers, spring washers and nuts supplied.

5. WINCH BARS: FITTING THE 10,000lb WINCH

- A. To place the winch clutch handle in a convenient location, the winch gearbox must be rotated 2 hole spacing, 72 degrees, in an anti clockwise direction when viewed from the gearbox end. Place the winch on its end and remove all gearbox bolts. Gently raise the gearbox just enough to rotate it. Do not completely remove the gearbox and avoid damaging the gasket. Refit all bolts and tighten. Refer to diagram 2C.
- B. Fit the roller fairlead into the front of the bull bar using the M12 x 30mm bolts, flat washers, spring washers and nuts supplied.
6. Attach the number plate to the front of the bull bar using the two M6 x 16mm bolts, flat washers and flange nuts supplied.
7. Fit the rubber buffers supplied to the bull bar using the M8 flange nuts supplied in the fitting kit.
8. Drill out the 4 forward most holes in the chassis rails with a 1/2" drill.
9. Slide the two Impact Absorbers over the chassis rails making sure the LH "Impact Absorber" is fitted to the LH side and the RH "Impact Absorber" is fitted to the RH side. Lift the winch mount cradle (**for winch bars only**) into position and loosely bolt in place using the 1/2" x 4 1/2" bolts, flat washers, spring washers and nuts in the top and rear chassis holes (the 40mm heavy duty washer must be located on the outside of the rear most hole) and the 1/2" x 5" bolt, flat washers, spring washer and nut in the lower forward chassis hole, passing through the steering arm protector. Refer to diagram 3. (The steering arm protector is not fitted to USA models). NOTE: Due to chassis rail width variations packers (numbers: 5846273 & 5846274), with fitting tabs, may need to be inserted between the "Impact Absorbers" and chassis rails.

DIAGRAM 3

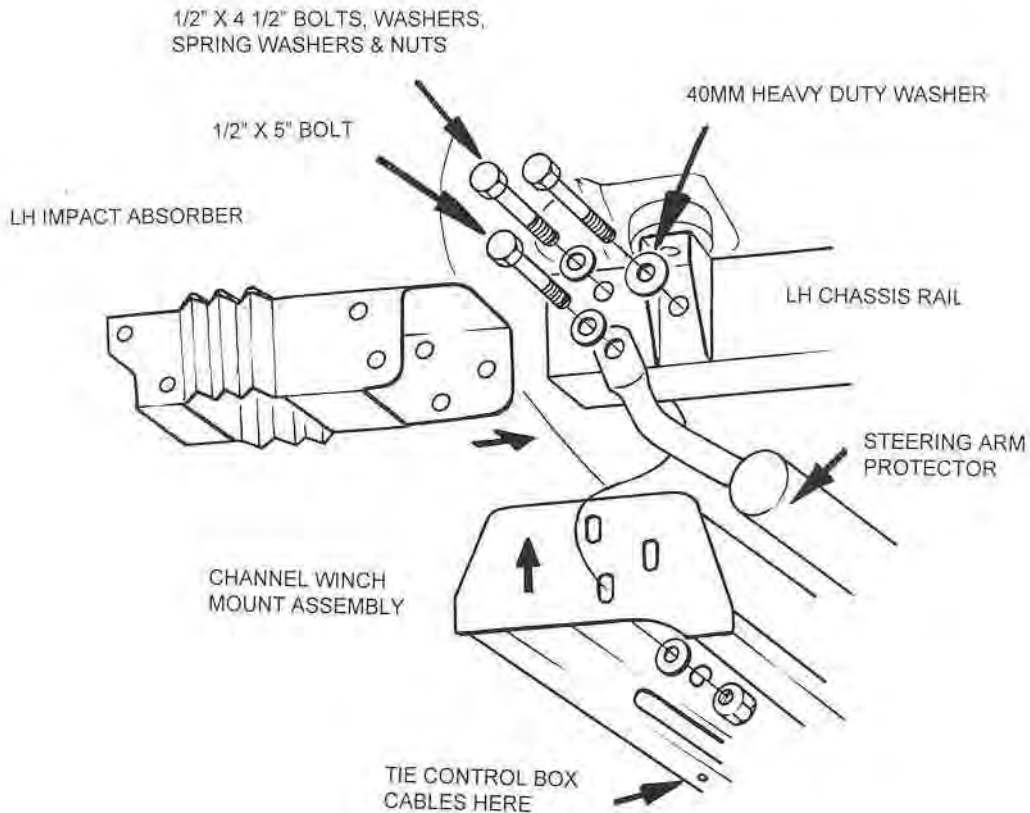

10. Using a level and a tape measure, adjust both Impact Absorbers so that they are parallel to each other, horizontal, and have an overall width of between 805mm and 808mm, then tighten the bolts. Refer to diagram 4.

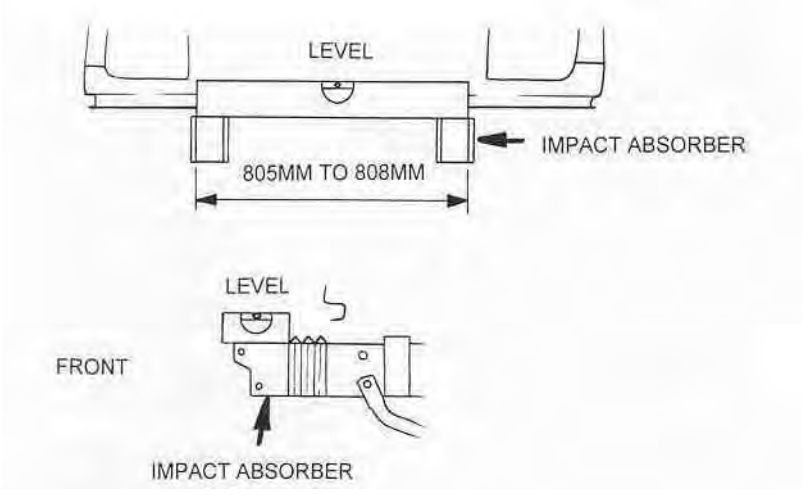

11. WINCH BARS ONLY:

A) Lift the winch into place and using the washers supplied in the fitting kit (3/8" for 8 or 9,000lb and 7/16" for 10,000lb) and the bolts and spring washers supplied with the winch, bolt securely into position. NOTE: The gearbox is on the LHS for the 8 & 9,000 winches and on the RHS for the 10,000lb winch. The winch cable spools from the bottom for all three winches.

- B) Wire the winch in accordance with the Warn fitting instructions, taking care not to route the cables over sharp edges. Tie the cables from the control box to the channel winch mount assembly using the cable tie supplied.
NOTE: Before running winch cables through the bar to control box be sure to fit rubber grommets to cutouts.

12. Lift the bull bar into place and loosely bolt to the two Impact Absorbers using the M10 x 25mm bolts, (4 per side) washers, spring washers and nuts. Refer to diagram 5.

DIAGRAM 5

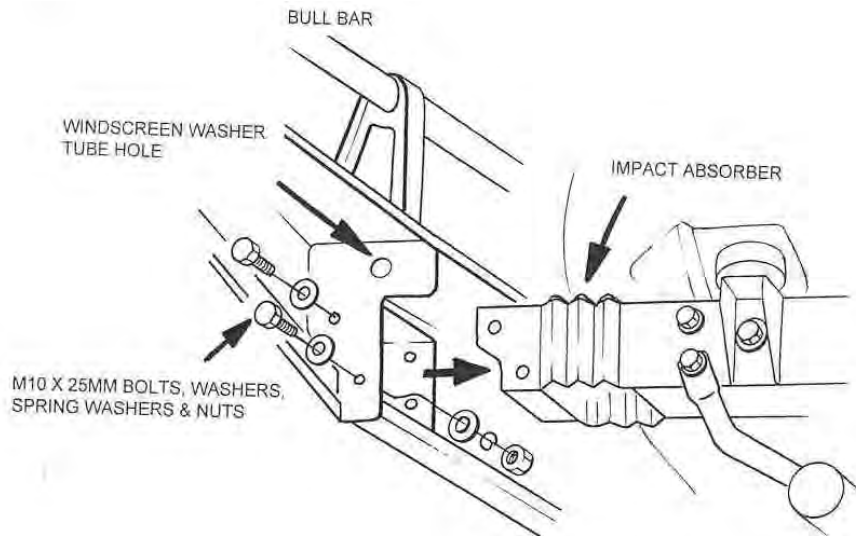

13. Adjust the bull bar until a uniform gap is achieved to the mud guards and grill. Securely tighten all bolts.
14. Connect the windscreen washer tube to the T piece and tighten the clamp.
15. **FOR WINCH BARS ONLY:** Fit the winch guard P# 3532030 (optional for 8 or 9,000lb Winch) to the bull bar and winch cradle using the M8 x 20mm bolts, flat washers, spring washers and nuts. Align the guard with the bull bar then tighten the bolts.

DIAGRAM 6

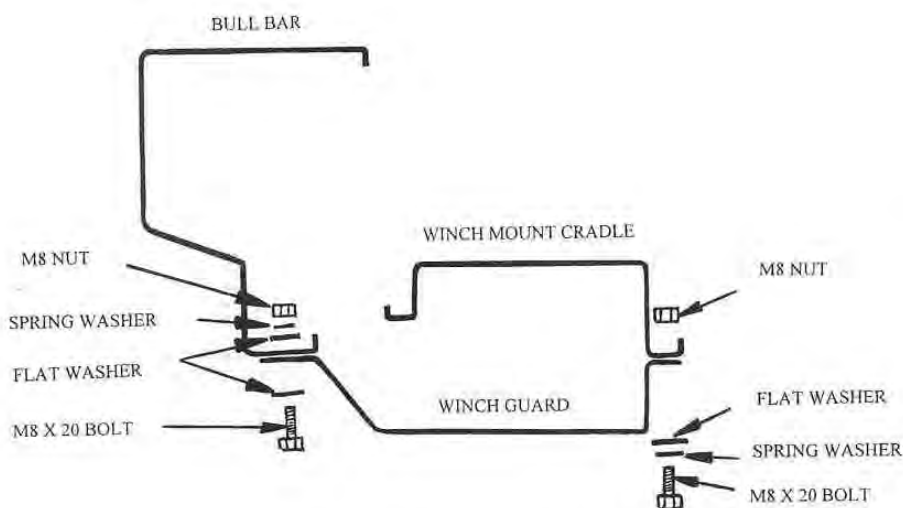

16. Connect the bull bar turn signal indicator looms to the existing turn signal indicator loom with the Scotchloks supplied and test to ensure they function correctly.