

# FITTING INSTRUCTIONS

## BP5190010L & BP5190010R

### TOYOTA TUNDRA 2007 On FRONT

### WARNING

- ◆ This product must be installed exactly as per these instructions using only the hardware supplied.
- ◆ In the event of damage to any suspension component, contact your nearest authorised ARB stockist. Repairs or modifications to the suspension system components must not be attempted.
- ◆ Do not use this product for any vehicle make or model, other than those specified by ARB.
- ◆ Do not remove labels from suspension components.
- ◆ This product or its fixing must not be modified in any way.
- ◆ The installation of this product may require the use of specialized tools and/or techniques
- ◆ It is recommended that this product is only installed by trained personnel
- ◆ These instructions are correct as at the publication date. ARB Corporation Ltd. cannot be held responsible for the impact of any changes subsequently made by the vehicle manufacturer
- ◆ During installation, it is the duty of the installer to check correct operation/clearances of all components
- ◆ Work safely at all times

**Note:** These fitting instructions should be read in conjunction with the vehicle workshop manual.

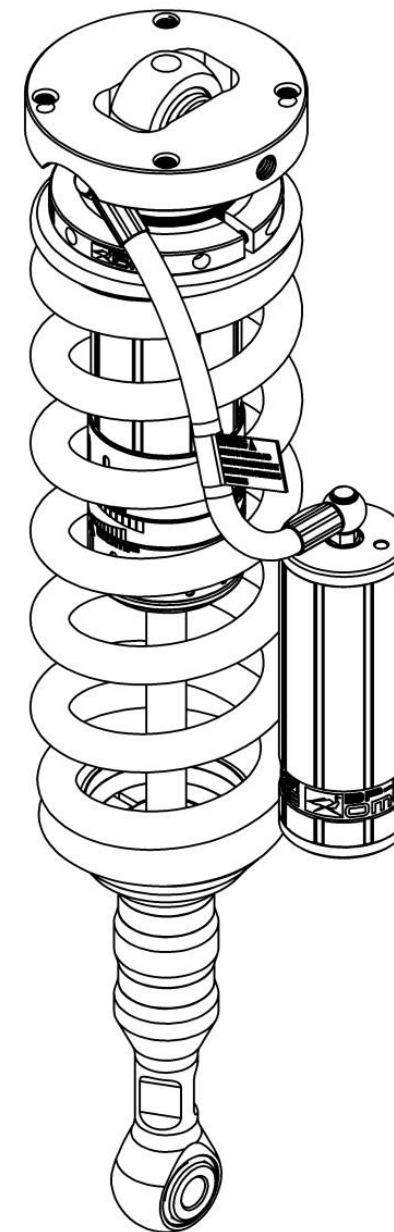

**FITTING KIT CONTENTS – VM80010034**

Item	Description	Kit Qty.	Spare Part No.
1	TOOL: ADJUSTER TOOL	1	VC10010071SP
2	MOUNT: RESERVOIR CLAMP	2	VE10010003SP
3	RESI MOUNT: TUNDRA FRONT	1	VE10020027LSP
		1	VE10020027RSP
4	BOLT KIT: M10x1.5x30	8	6151555Q8SP
5	WASHER: M6 BLACK	4	VE70020005SP
6	BOLT: M6 X 16	4	VD60030003SP
7	NUT: M6 NYLOC	4	VD60010003SP

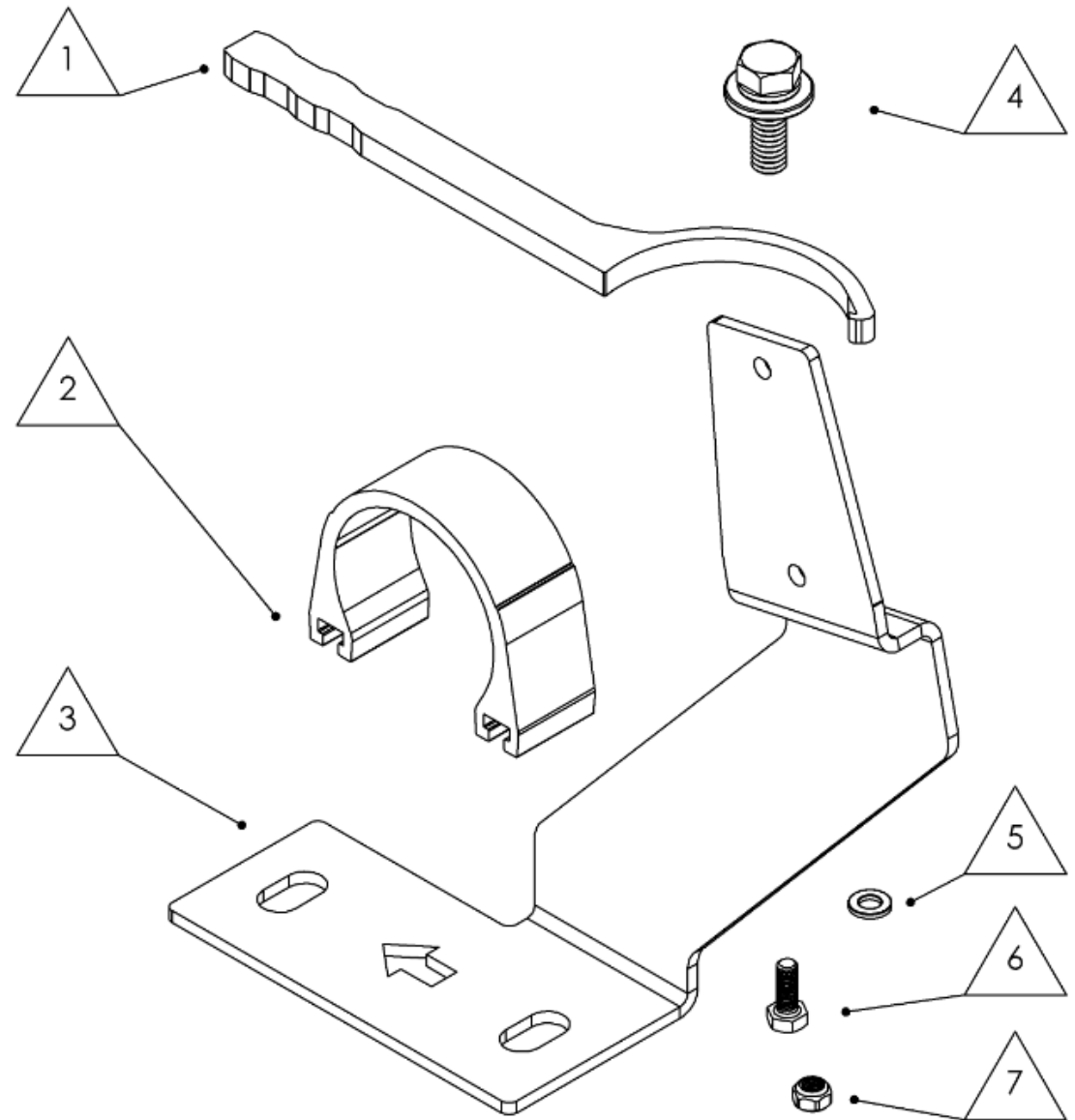

## DAMPER PREPARATION

Before fitment the spring preload may need to be adjusted to suit your front accessory fitment and desired ride height.

Use workshop tool kit **VM80020001** and **VM80020023** to aid spring adjustment.

The spring preload is set at the factory to **10mm** as shown by the diagram. This aims to achieve **50mm** increase in ride height over OE when no accessories and winch are fitted.

It is required to set the preload before the strut assembly is fitted to the vehicle. Use a spring compressor to compress the spring, loosen the pinch bolt on the preload ring and adjust to the desired setting. Tighten the pinch bolt and remove the strut assembly from the spring compressor.

As a guide, set the preload as specified below to achieve 50mm lift over OE.

<u>Front accessories</u>	<u>Preload</u>
Bar & winch	25 mm
Bar only	20 mm
No accessories	10 mm

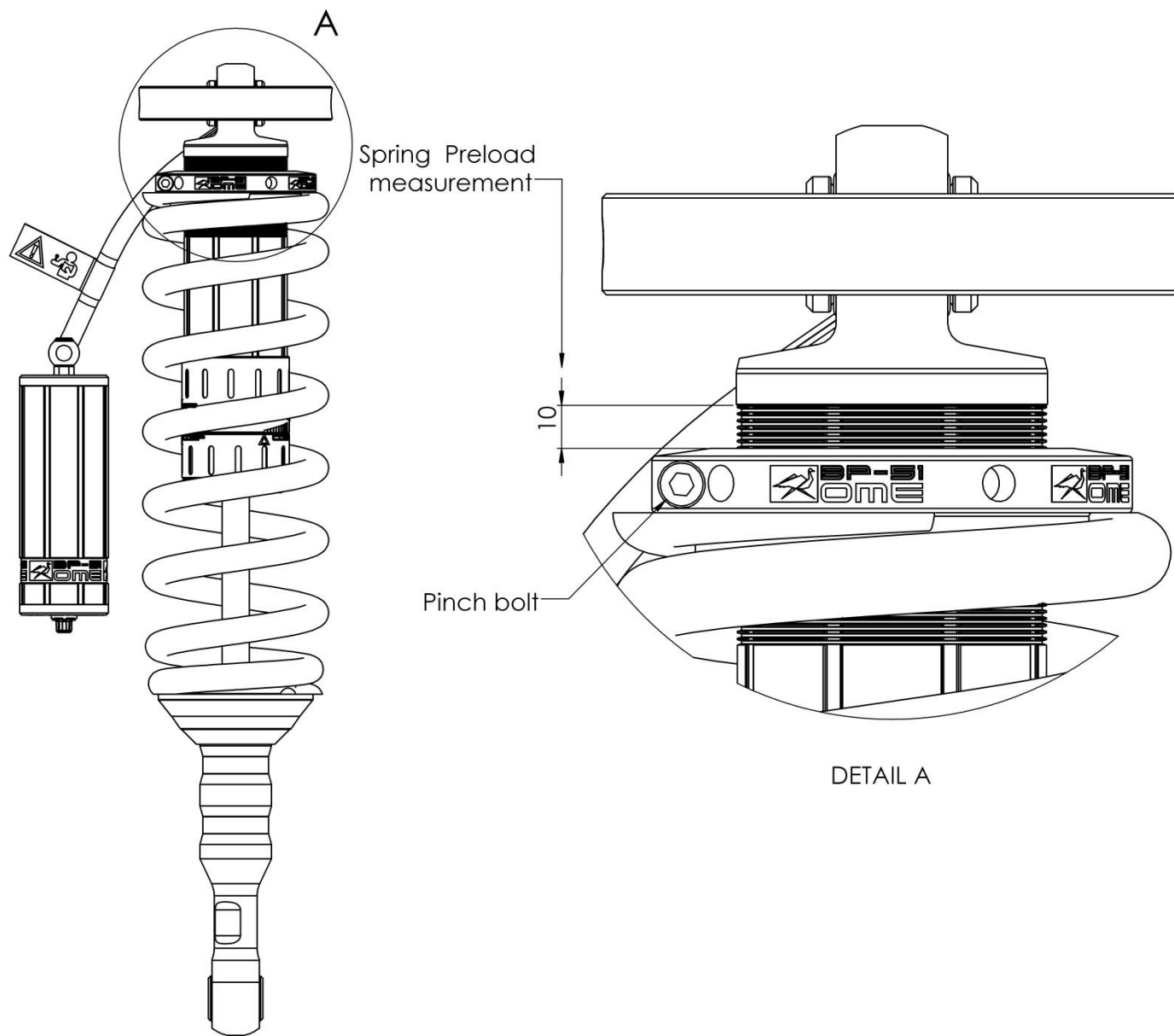

## DAMPER MOUNTING SEQUENCE

Remove old dampers from vehicle.

(For LHS and RHS detach sway bar link from lower arm (1) and steering tie rod end from upright (2). Loosen two bolts that secure the lower arm to the upright (3).)

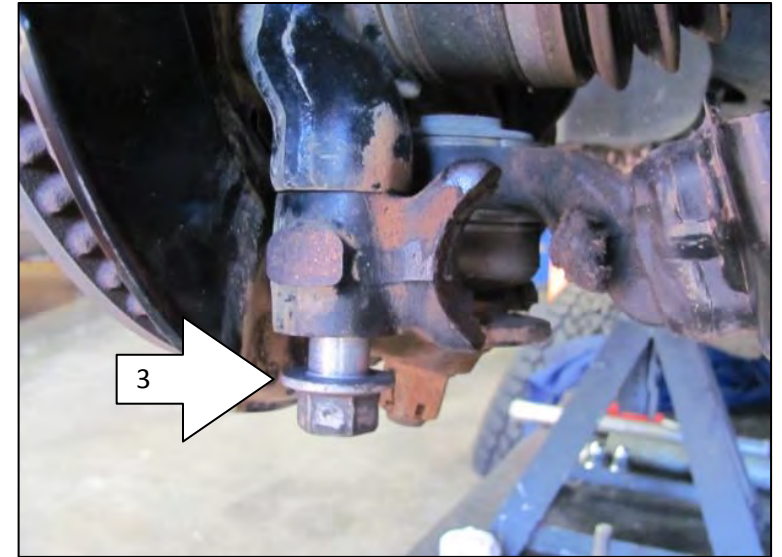
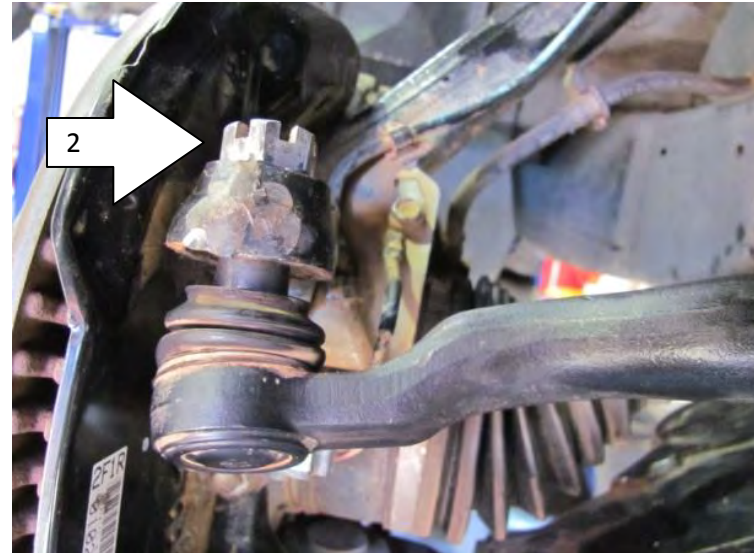
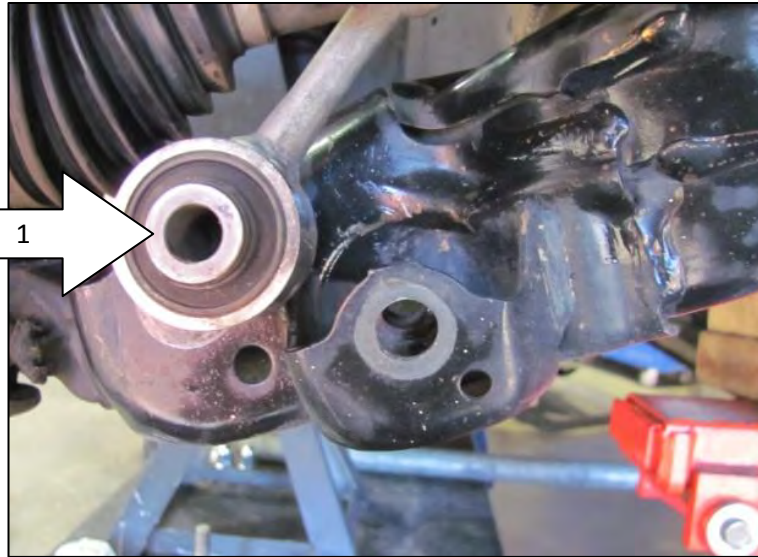

## DAMPER MOUNTING SEQUENCE

Fit the damper and secure the top mount with the new M10 hardware supplied. Secure finger tight. (RH shown)

When mounted in the vehicle the hose and reservoir should be towards the front.

Secure bottom mount using original bolt and nut.

Torque all fasteners as per diagram and table below.



Fastener	Torque N.m (ft.lbf)
Sway bar link to lower control arm	135 (100)
Steering tie rod end to upright	69 (51)
Lower control arm to upright	300 (221)
Strut top hat	44 (32)
Strut to lower control arm	180 (133)

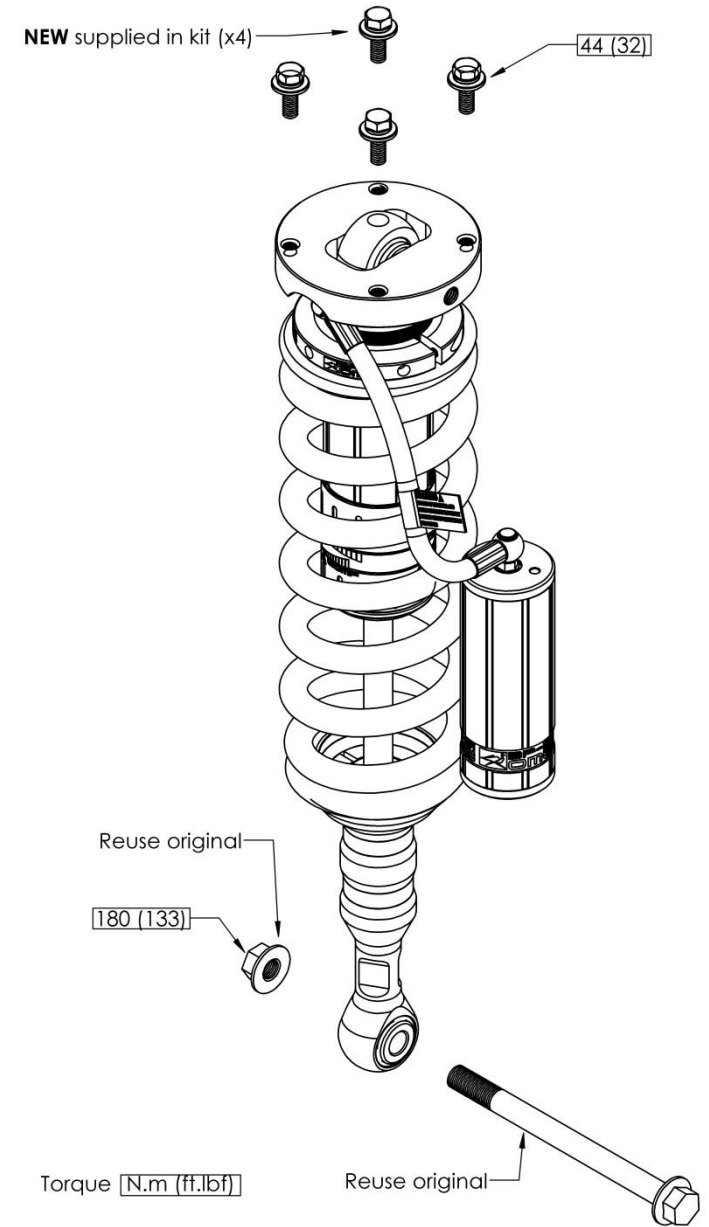

## RESERVOIR MOUNTING SEQUENCE

1. Fit M6 bolts to Resi Mount VE10020016L/R and secure with nyloc nut and flat washer finger tight only
2. Fit the resi mounting bracket by removing the front fixed swaybar mount and installing the new resi bracket in between the chassis and sway bar mount. Reuse existing bolts to secure the bracket. Tighten securely.
3. Fit the mounting saddle to the reservoir and slide over the heads of the bolts in the Resi Mount.
4. Position the saddle on the plate and adjust the position of the reservoir as shown

Ensure the hose is well routed from the damper body cap to the reservoir without kinks and with clearance to the upper control arm.

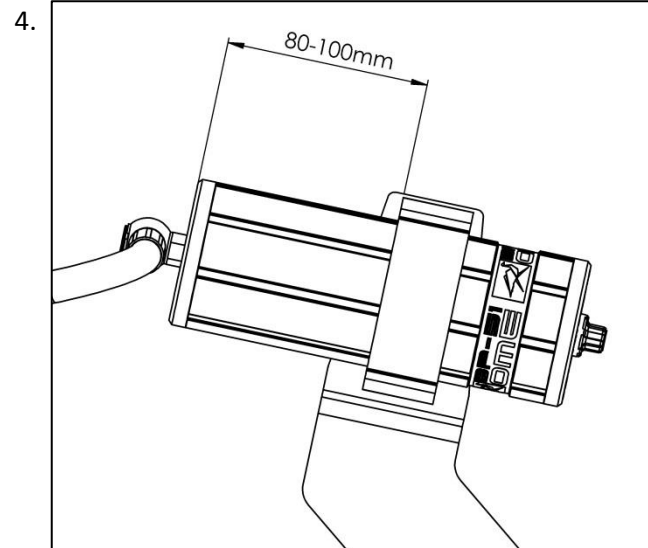
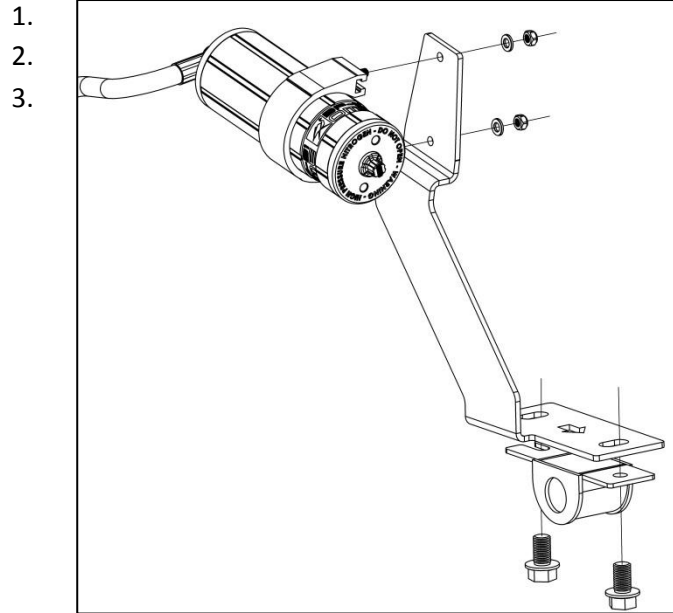

## SPECIFICATIONS AND SPARE PARTS

Item	Description	Part No./Specification
1	Spare Part: Spherical Bearing	VD10010019SP
2	Specification: Factory Preload Setting	10 mm
3	Spare Part: Hose	VD81033180SP
4	Spare Part: Oil	VM80020015
5	Specification: Factory Rebound Setting	6
6	Specification: Factory Compression Setting	4 </td
7	Specification: Nitrogen Pressure	2000 kPa / 290 PSI
8	Spare Part: Resi Valve Kit	VM80030001SP
9	Spare Part: Spherical Bearing	VD10010019SP
10	Spare Part: Damper Mounting Kit	VM80010034

## DAMPING ADJUSTMENT

These dampers have been set in the factory to be used for a vehicle with Bull Bar and winch fitted. If your accessory fitment differs, use the table below as a guide for recommended compression (Comp) and rebound (Reb) adjuster settings. Refer to the Owner's Manual for more information.

Front accessories	Comp	Reb
Bar & winch	4-8	7-10
Bar only	2-6	6-10
No accessories	0-4	6-10

