



FITTING INSTRUCTIONS

Part Number: 4421100, 4421110, 4421120, 4421130

Product

Description: **SIDE STEP/ FRONT RAIL /STEP RETURNS**

Suited to

vehicle/s: **TOYOTA LANDCRUISER PRADO 150 2009 ON ***NON KDSS ONLY*****

TOYOTA LANDCRUISER PRADO 150 2017 ON *NON KDSS ONLY*****

WARNING

REGARDING VEHICLES EQUIPPED WITH SIDE AIR CURTAINS & SIDE AIRBAGS:

When installed in accordance with these instructions, the Side Step and Side Rail does not affect operation of the Side Air Curtains and Side Airbags.

ALSO, NOTE THE FOLLOWING:

- ◆ This product must be installed exactly as per these instructions using only the hardware supplied.
- ◆ In the event of damage to any Side Step and Side Rail component, contact your nearest authorised ARB stockist. Repairs or modifications to the impact absorption system must not be attempted.
- ◆ Do not use this product for any vehicle make or model, other than those specified by ARB.
- ◆ This product or its fixing must not be modified in any way.
- ◆ The installation of this product may require the use of specialized tools and/or techniques
- ◆ It is recommended that this product is only installed by trained personnel
- ◆ These instructions are correct as at the publication date. ARB Corporation Ltd. cannot be held responsible for the impact of any changes subsequently made by the vehicle manufacturer
- ◆ During installation, it is the duty of the installer to check correct operation/clearances of all components
- ◆ Work safely at all times
- ◆ Unless otherwise instructed, tighten fasteners to specified torque

ARB 4x4 ACCESSORIES

Corporate Head Office

42-44 Garden St
Kilsyth, Victoria
AUSTRALIA 3137

Tel: +61 (3) 9761 6622
Fax: +61 (3) 9761 6807

Australian enquiries
North & South American enquiries
Other international enquiries

sales@arb.com.au
sales@arbusa.com
exports@arb.com.au

www.arb.com.au

GENERAL CARE AND MAINTENANCE

By choosing an ARB Side Step and Side Rail, you have bought a product that is one of the most sought after 4WD products in the world. Your step and rail is a properly engineered, reliable, quality accessory that represents excellent value. To keep your step and rail in original condition it is important to care and maintain it following these recommendations:



- Prior to exposure to the weather your step and rail should be treated to a Canuba based polish on all exposed surfaces. It is recommended that this is performed on a six monthly basis or following exposure to salt, mud, sand or other contaminants.
- As part of any Pre Trip Preparation, or on an annual basis, it is recommended that a thorough visual inspection of the step and rail and surrounding components is carried out, making sure that all bolts are torqued to the correct specification. Also check that nearby wiring and plumbing are free of damage. Replace any components as necessary. This service can be performed by your local authorized ARB Stockist.

FITTING REQUIREMENTS

REQUIRED TOOLS FOR FITMENT OF PRODUCT:

METRIC SOCKET SET	METRIC COMBINATION SPANNER SET
ELECTRIC DRILL Ø 13 MM CAPACITY	Ø 4,6.5, 8.5, 12 mm DRILL BITS
PHILLIPS AND FLAT BLADED SCREW DRIVER SET	METRIC MEASURE TAPE
BLACK SILICONE	STEEL RULE 0-300 mm
HAMMER	STEP DRILL UP TO Ø 24mm
CENTRE PUNCH	MARKER PEN
SCISSORS	SMALL FLAT & ROUND FILES
RUST PREVENTIVE PAINT	ALLEN KEY SET
TORQUE WRENCH 9-77Nm	AXLE STANDS (OPTIONAL)
RIVET GUN FOR 2.7mm SHANK RIVETS	PVC TAPE

HAVE AVAILABLE THESE SAFETY ITEMS WHEN FITTING PRODUCT:

Protective eyewear		Hearing protection	
--------------------	---	--------------------	---

NOTE: 'WARNING' notes in the fitting procedure relate to OHS situations, where to avoid a potentially hazardous situation it is suggested that protective safety gear be worn or a safe work procedure be employed. If these notes and warnings are not heeded, injury may result.

FASTENER TORQUE SETTINGS:

SIZE	Torque Nm	Torque lbft
M6	9Nm	7lbft
M8	22Nm	16lbft
M10	44Nm	32lbft
M12	77Nm	57lbft

PARTS LISTING

APPLICATION.	PART NO.	QTY	DESCRIPTION
Step to chassis (4421100)	6562738R	1	Rail side step RHS
	6562738L	1	Rail side step LHS
	6151509	4	Bolt M10 x 1.5 x 110
	6151577	4	Bolt M10 X 1.5 X 155
	6151456	2	Bolt M10 x 1.5 x 45
	6151240	2	Bolt M8 x 1.25 x 50
	6151550	2	Bolt M6 x 1.0 x 25
	6151321	4	Nut Flange M10 x 1.5 ZP
	4581048	6	Washer Spring M10
	4581046	2	Washer Spring M8 ZP
	6151042	2	Washer Spring M6 ZP
	4581040	10	Washer Flat, M10 x 25 x 3 ZP
	4584336	2	Washer Flat M8 x 17 x 1.6
	4584348	2	Washer Flat x 12.2 x 1.25
	3194373	4	Plate spacer 8mm
	3194374	4	Plate spacer 10mm
	5811067	4	Sleeve Mount
	4721749	2	Tube Spacer 19MM
	3194901	2	Plate Threaded 8MM
	6151300	2	Nut Captive M6 x 1.0
	4654084	2	NUT PLATE M10X1.5
	6151596	2	P Clip 19MM
6500002	2	Plug rubber 60.3 tube	
215637	2	Decal ARB side steps	
Protection step end section (4421120)	6562742R	1	Side rail front section assembly RH
	6562742L	1	Side rail front section assembly LH
	3195142R	1	Tread Plate R/Rail RH
	3195142L	1	Tread Plate R/Rail LH
	6151256	16	Screw BTN HD M6 x 16
	4581072	16	Washer panel 1/4"
	6151162	16	Nut flange M6
	6151022	4	Hex bolt M8 x 25 zp
	4581044	8	Washer flat M8
	6151032	4	Nut nyloc M8 zp
	6250024	4	Spacer S/Step
	6500002	2	Plug 60.3 Tube
Front rails (4421110)	6562740R	1	Side rail front rail assembly RH
	6562740L	1	Side rail front rail assembly LH
Front rails (4421130)	6562783R	1	Side rail front rail assembly RH
	6562783L	1	Side rail front rail assembly LH
Front rails (Common Components)	3195143R	1	Tread Plate RH
	3195143L	1	Tread Plate LH
	6151256	16	Screw BTN HD M6 x 16
	4581072	16	Washer panel 1/4"
	6151128	16	Nut flange M6
	6582464	1	Clamp Kit S/RAIL
	6151022	4	Hex bolt M8 x 25 zp
	4581044	8	Washer flat M8
	6151032	4	Nut nyloc M8 zp
	6250024	4	Spacer S/STEP
	3789336	1	Template S/Rail Clamp
OEM lights to step (If fitted)	6151440	12	Rivet Blind 3/16
	180302	8	Cable ties

FITTING PROCEDURE



1. If fitted, remove the factory side steps retaining all fasteners.
2. Refit the fasteners into the captive nuts in the vehicles body to seal against water ingress.



3. Place jack underneath the transmission cross-member and adjust so that the transmission is supported, as shown.



4. Remove 2 x transmission cross-member bolts as shown. (LH side of vehicle shown)



5. Place a 10mm spacer plate and an 8mm spacer together creating an 18mm spacer and tape together as shown. Do the same with the other spacers to make two 18mm spacers for the RH side and two for the LH side mounting.

FITTING PROCEDURE



6. If fitted with factory side step lights remove by depressing plastic clips, and unbolting to separate plastic cover from aluminium extrusion to expose the rivets fastening the light brackets to the step, drill out the rivets. Repeat on both steps.



Warning: Drilling operations can result in flying metal debris, safety glasses should be worn.

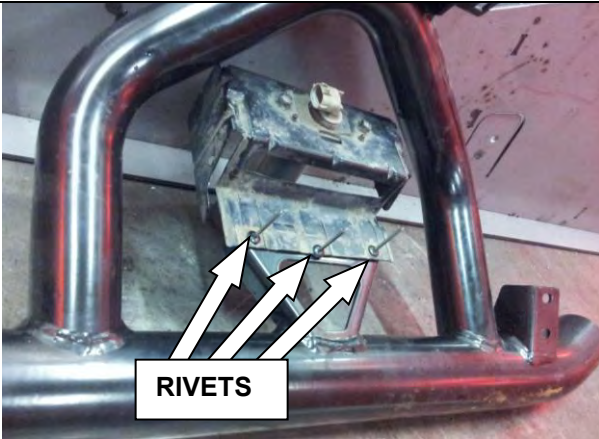

7. Rivet the factory step lights to the side step as shown. Repeat on both LH and RH steps.



8. Remove 2 M8 bolts retaining the hand brake cable to the outside of chassis rail at rear wheel on both sides.



9. Fit the rubber plugs into the rear most ends of the RH and LH side rails.

FITTING PROCEDURE



10. With the help of a friend place the RHS side step in place by sliding the front bracket over the transmission cross-member and the rear bracket mount under the hand brake cable as shown. Support the side step in position with axle stands or the aid of a friend.

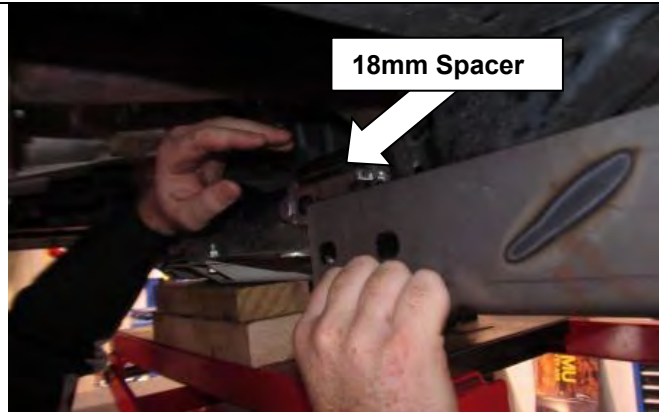

11. **NOTE: Ensure spacers are placed as shown with open end facing outward**



12. Pre-bend the nut plates into suitable profiles. Bend tail up approx. 30 degrees.

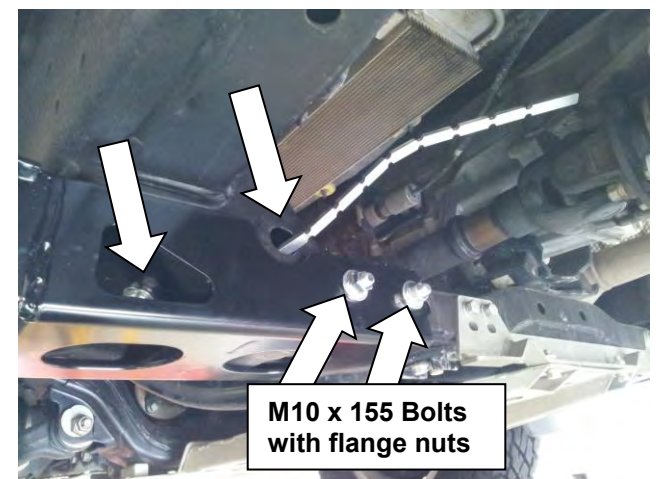

13. Loosely fasten in place using supplied 155mm long M10 bolts, M10 spring washers, M10 flat washers under the bolt head and M10 flange nuts.

14. Now thread nut plates into the chassis as shown, and loosely fasten the front bracket with M10 x 45 mm bolt, M10 spring washer and M10 flat washer.

Torque to Specification.

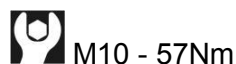

FITTING PROCEDURE



15. At the rear mount, using the fasteners shown fit the threaded plate to the inside face of the chassis rail.

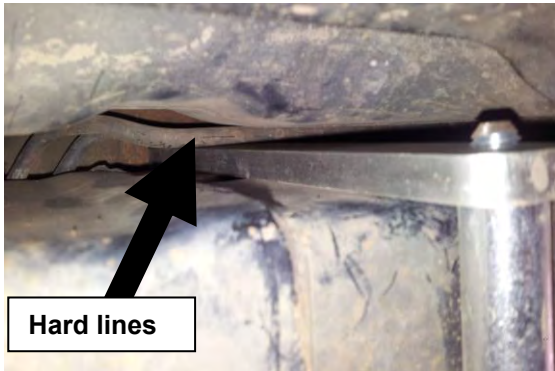

16. On the L/H side of the vehicle this plate will go under any hard lines attached to the chassis rail. **Take care not to damage any hard lines.**



17. Fit bottom bolt and spacer first to help align thread plate while inserting top bolt and spacer.

Align step to sill of vehicle.

Torque to Specification.

 M10 - 57Nm

FITTING PROCEDURE

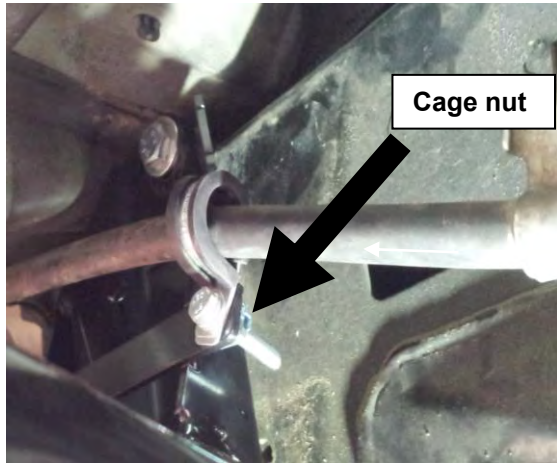

18. Clip M6 Cage nut into the square hole in the rear mount. Using M6 bolt with spring and flat washer install the P clip around the hand brake cable and screw into the captive nut as shown.

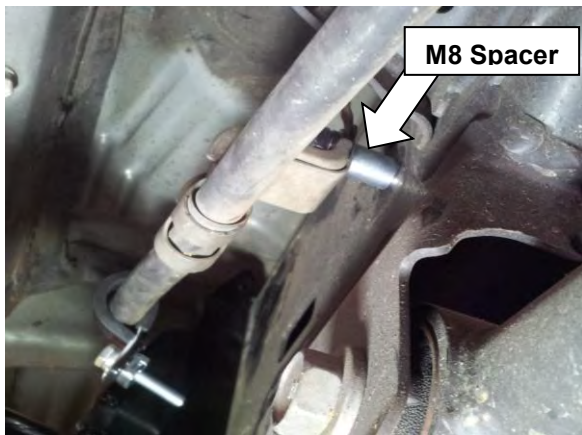
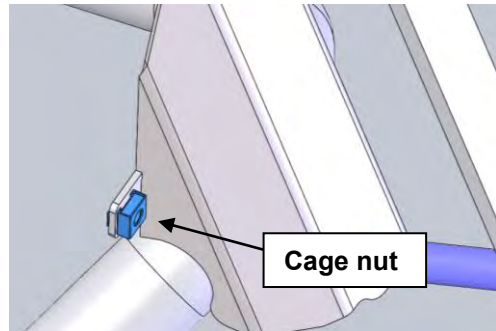

19. Use the M8 x 40 bolt with spring & flat washers through the rear OE brake cable bracket to refit the brake cable to chassis. Install the spacer from the kit to correctly align the hand brake cable.

Torque to Specification.



M8 - 22Nm

20. If applicable plug the step light loom anchor points back to vehicle and cable tie loom to vehicle chassis on both RHS and LHS.

FITTING PROCEDURE

FRONT SIDE RAIL FITMENT TO VEHICLE (4421110) OR (4421130)

IF NOT FITTING SIDE RAIL GO TO STEP 36.

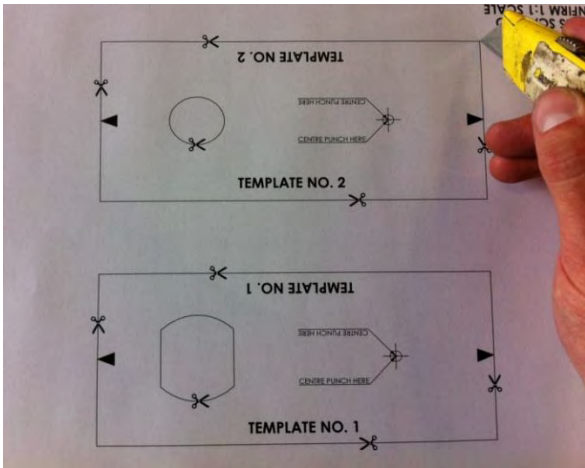

1. Using Scissors or a Stanley Knife carefully cut out Templates 1 and 2 including the 2 x pieces from the inside – (See image).



2. Use masking tape to wrap **1 x layer only** of tape around the Bull Bar Outer Frame parallel section to protect it from damage as shown. Ensure masking tape is applied flat and without creases.

WARNING: If more than 1 x layer of masking tape is applied and/or creases are present it will affect the use of the drilling templates and could result in the Bull Bar being incorrectly drilled and not serviceable.

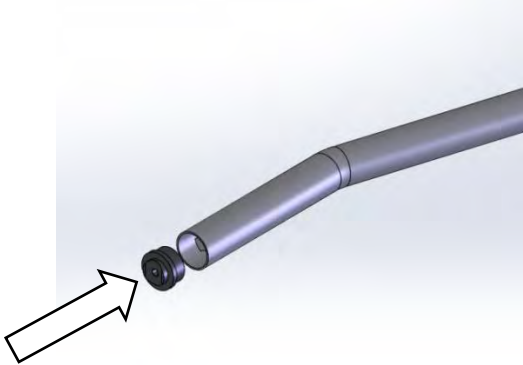

3. Install Tube Spigot into the front of the Side Rail.

Note: Install without spacers fitted.

FRONT SIDE RAIL FITMENT TO VEHICLE - CONTINUED

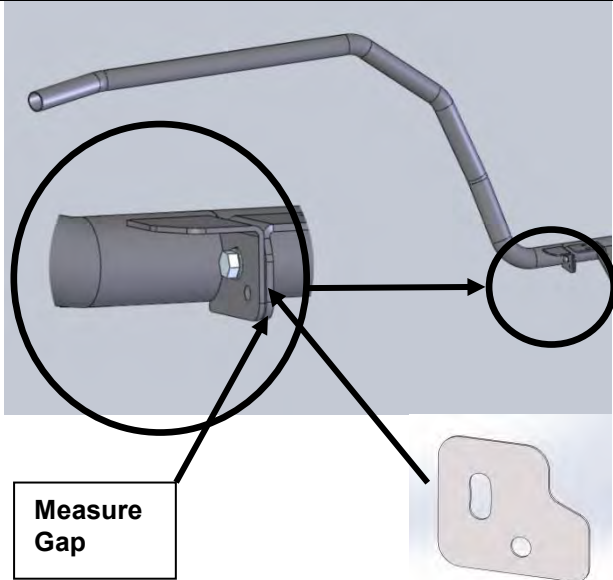

4. On the RH side, place the Front Side Rail assembly onto the end of the Side Step Rear section as shown and attach using an M8X25 Bolt, 2 x M8 Flat Washers and an M8 Nyloc Nut. Measure gap.

Note: Up to 3 x 6250024 - SPACER S/STEP / RETURN LG RAD may be installed between Side Step and Side Rail Brackets to fill gap.

Note: Do not fully tighten at this stage.



5. Hold Side Rail so that when viewed from the side of the vehicle the top tube is horizontal (**parallel to the ground**) and the Side Rail sits as desired against the side of the vehicle.
6. Offer Side Rail/Tube Spigot up to the back of the Bull Bar outer frame. – If a gap exists slide Tube Spigot forwards until it contacts the Bull Bar outer frame.



7. **CRITICAL:** Set distance from top face of the bull bar wing to bottom of rail to 80mm +/- 2mm for correct set up.

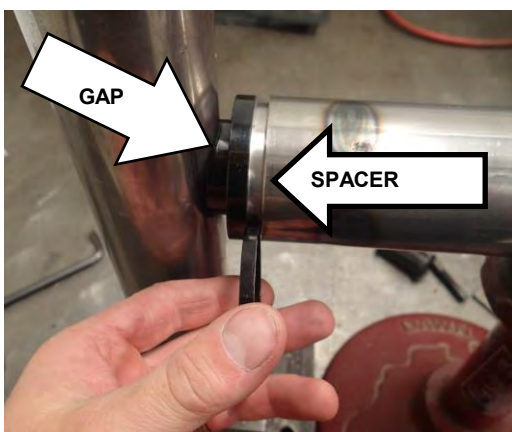

8. Assess the gap between the front end of the Side Rail and the Tube Spigot. Select the closest matching Spacer/Spacers to fill the gap. (Spacer options: Nil / 5mm / 10mm or 15mm (5mm + 10mm Spacers).

Note: If the gap is too large for the Spacers to fill or too small (ie. the tube spigot cannot be fitted) adjustment of the Bull Bar and/or Side Step may be required.

FRONT SIDE RAIL FITMENT TO VEHICLE - CONTINUED



9. Swing the Side Rail outwards and away from the vehicle allowing installation of appropriate/selected spacer into gap between the front end of the Side Rail and the Tube Spigot. (5mm in this instance).

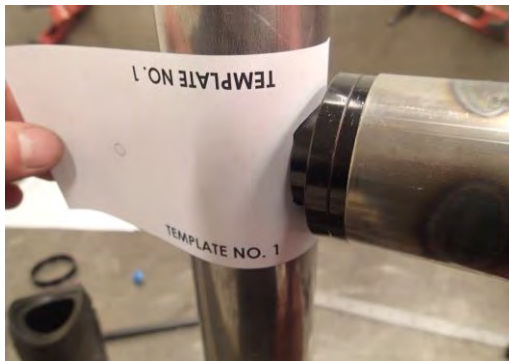

10. Swing the Side Rail inwards and install "TEMPLATE 1" between the end of the Tube Spigot and the Bull Bar outer frame.



11. Carefully align and centre "TEMPLATE 1" with the end of the Tube Spigot and wrap around the Outer Frame Tube.

Note: Ensure the indicator arrows are aligned before taping into position with Masking Tape – (AS SHOWN).

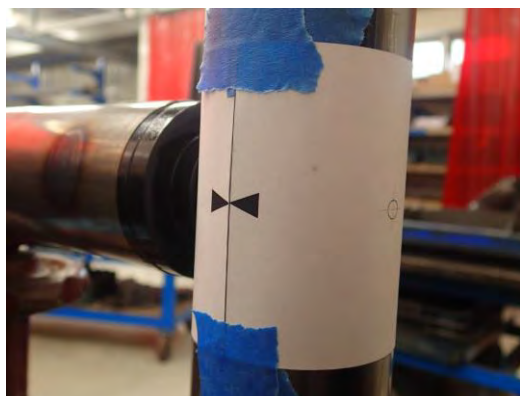

FRONT SIDE RAIL FITMENT TO VEHICLE - CONTINUED



- Using a Centre Punch, carefully Centre Punch the outer frame at the centre mark of "TEMPLATE 1".
- Remove Side Rail and set aside.
- Remove "TEMPLATE 1".

Note: Do not discard. Template will be re-used for the opposite side clamp installation.



Warning: Hammering can result in flying metal debris, safety glasses should be worn.

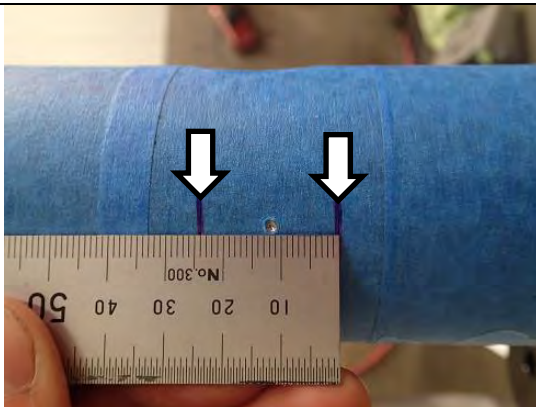

- Using a marker pen, mark the outer frame 12mm above and below the Centre Punch mark (12mm + 12mm = 24mm).

Note: These marks on the outer frame give an indication of how far to drill with the Stepped Drill.

- Using a marker pen, mark the Ø24mm step on the Stepped Drill.

Note: These marks on the Stepped Drill give an indication of how far to drill to achieve the correct diameter hole in the outer frame.

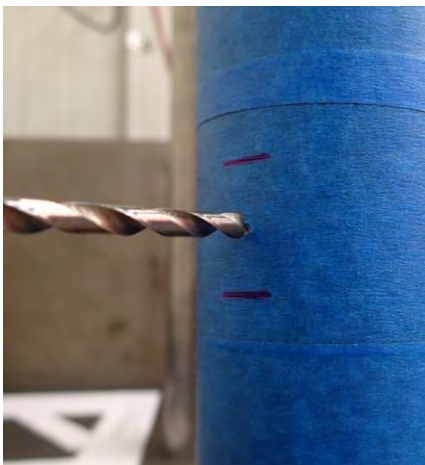

- At the location of the Centre Punch mark, use an Ø4mm (or similarly sized) Drill Bit to drill a pilot hole through the front face of the Bull Bar outer frame.



Warning: Drilling operations can result in flying metal debris, safety glasses should be worn.

FRONT SIDE RAIL FITMENT TO VEHICLE - CONTINUED

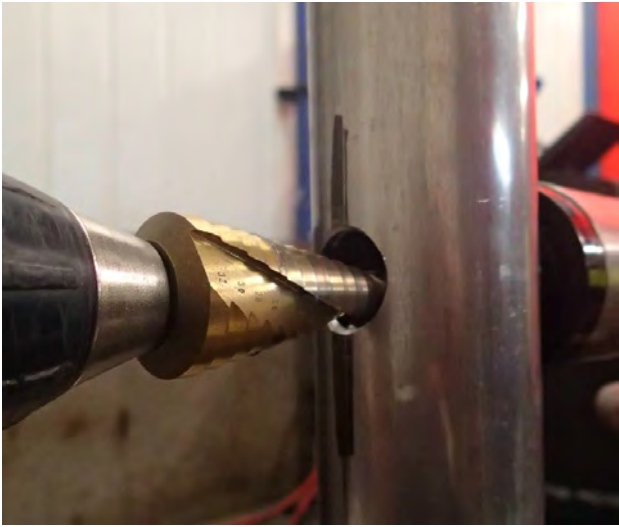

18. Use a Stepped Drill Bit to drill the $\text{\O}4\text{mm}$ pilot hole out to $\text{\O}24\text{mm}$.

WARNING - Do not drill past the 24mm marks on the outer frame or the $\text{\O}24\text{mm}$ mark on the Stepped Drill - Drilling too far will destroy the Bull Bar.



Warning: Drilling operations can result in flying metal debris, safety glasses should be worn.



19. Using a small Round or Half-Round File carefully remove any burrs from the edge of the $\text{\O}24\text{mm}$ hole.

Note: Care should be taken to avoid damaging the outer frame paintwork surrounding the $\text{\O}24\text{mm}$ hole.

FRONT SIDE RAIL FITMENT TO VEHICLE - CONTINUED

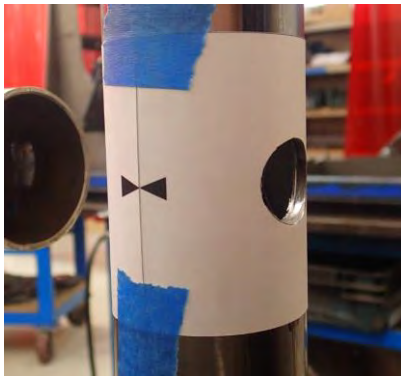

20. Carefully align "TEMPLATE 2" and centre over the Ø24mm hole. Wrap around the Outer Frame Tube.

Note: Ensure the indicator arrows are aligned before taping into position with Masking Tape – (AS SHOWN).

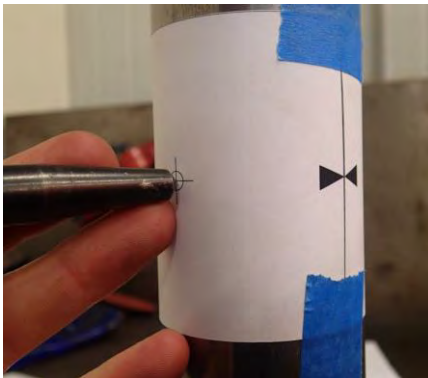

21. Using a Centre Punch, carefully Centre Punch the outer frame at the centre mark of "TEMPLATE 2".
22. Remove "TEMPLATE 2".

Note: Do not discard. Template will be re-used for the opposite side clamp installation.



Warning: Hammering can result in flying metal debris, safety glasses should be worn.

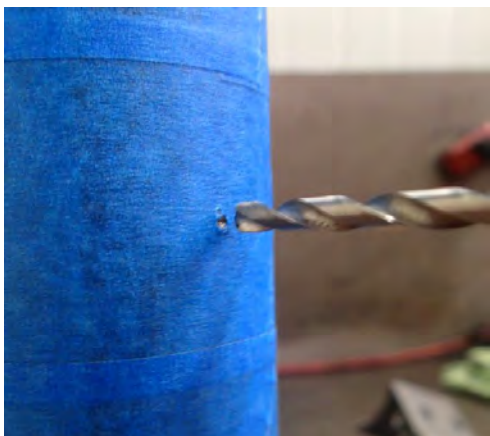

23. At the location of the Centre Punch mark, use an Ø4mm (or similarly sized) Drill Bit to drill a pilot hole through the front face of the Bull Bar outer frame.
24. Use an Ø12mm Drill Bit to drill the Ø4mm pilot hole out to Ø12mm.



Warning: Drilling operations can result in flying metal debris, safety glasses should be worn.

FRONT SIDE RAIL FITMENT TO VEHICLE - CONTINUED



25. Using a small Flat or Half-Round File carefully remove any burrs from the edge of the Ø12mm hole.

Note: Care should be taken to avoid damaging the outer frame paintwork surrounding the Ø12mm hole.

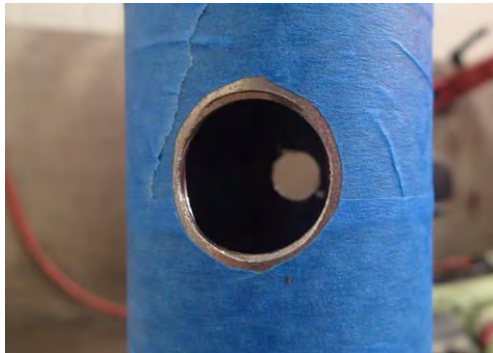

26. Clean and paint with Rust Preventative Paint any exposed/bare metal surfaces left after drilling.

Note: Use tape/paper to mask surrounding areas to avoid getting paint overspray in undesired locations.

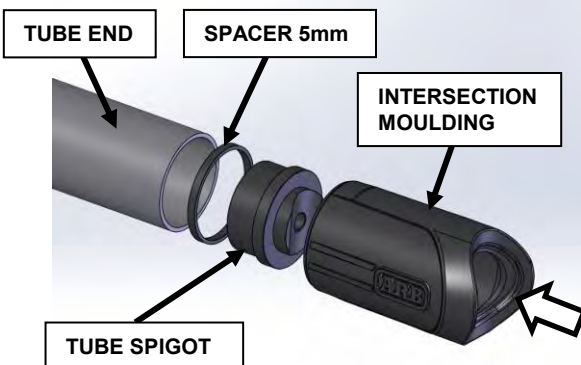

27. Install Tube Spigot, selected Spacer/Spacers and Intersection Moulding into place on the Side Rail.

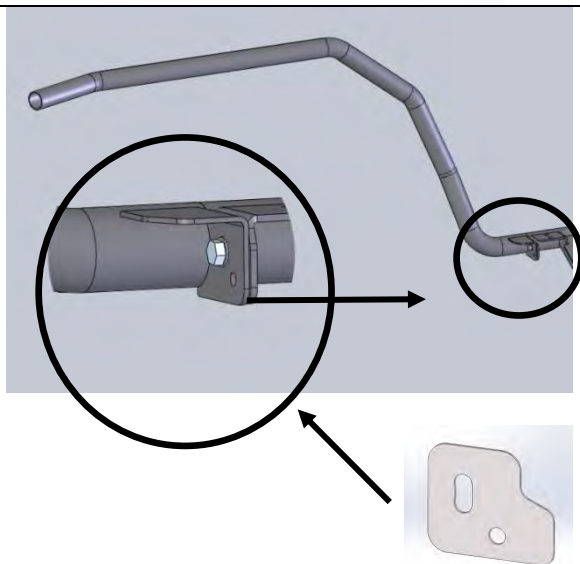

28. Install Side Rail (with clamp components fitted) onto Side Step spigot and attach using an M8X20 Bolt, 2 x M8 Flat Washers and an M8 Nyloc Nut.

Note: Up to 3 x 6250024 - SPACER S/STEP / RETURN LG RAD may be installed between Side Step and Side Rail Brackets to obtain better fitment.

Note: Do not fully tighten at this stage.

FRONT SIDE RAIL FITMENT TO VEHICLE - CONTINUED



29. Install Submerged Bush and M10 Bolt.

Torque to Specification.



M10 - 57Nm **(CRITICAL)**.



30. Set rail gap to vehicle fender 30mm +/- 3mm.

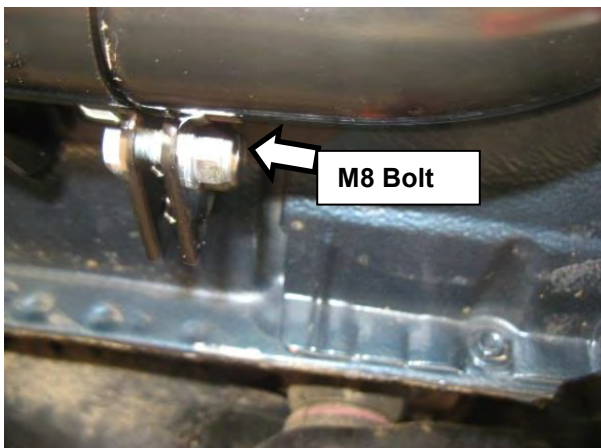

31. With suitable packer set installed between flanges to eliminate gap.
32. Tighten M8 Bolt ensure the slot and holes in the 6250024- SPACER S/STEP / RETURN LG RAD are aligned with the holes in the Step / Side Rail Brackets.

Torque to Specification.



M8 - 22Nm

FRONT SIDE RAIL FITMENT TO VEHICLE - CONTINUED

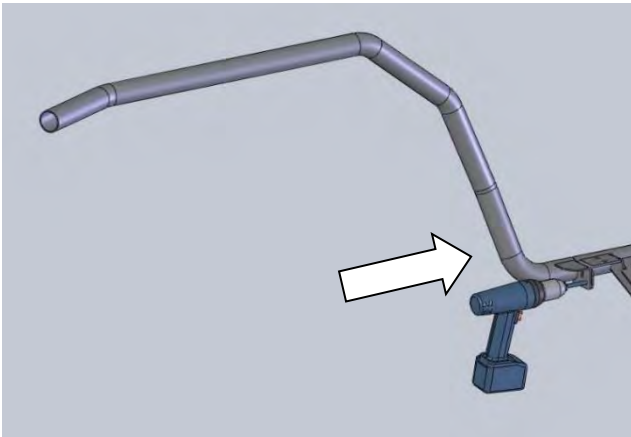

33. Using an electric drill with an Ø8mm drill bit and the pre-cut hole in the front side rail as a guide, drill through the rear section.

NOTE: IT MAY BE NECESSARY TO TEMPORARILY REMOVE THE MUD FLAPS TO GAIN ACCESS WITH THE DRILL.

34. Apply paint or a rust preventative to the bare metal.



Warning: Drilling operations can result in flying metal debris, safety glasses should be worn.

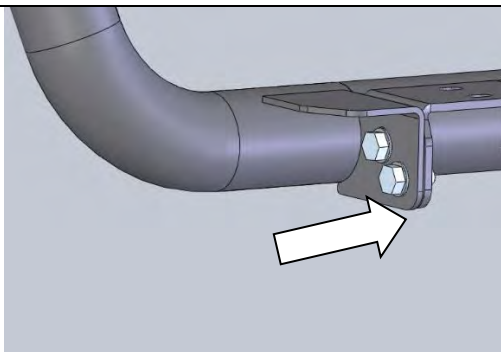

35. Pin the front side rail to the rear section using an M8X25 Bolt, 2 x M8 Flat Washers and an M8 Nyloc Nut.

Repeat step 1 – 33 on other side.

Torque to Specification.



SIDE STEP RETURN FITMENT TO VEHICLE.(4421120)

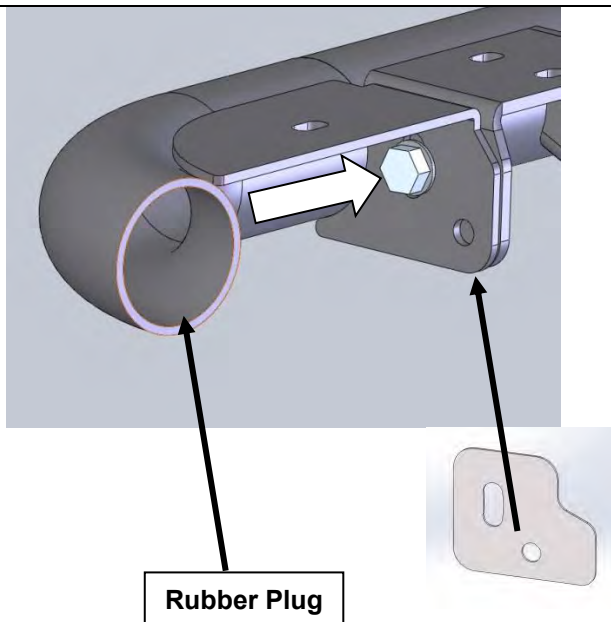

FITTING CURVED END SECTIONS

36. On the RH side fit the curved end section onto the side rail as shown and attach using an M8X20 Bolt, 2 x M8 Flat Washers and an M8 Nyloc Nut. Install rubber plug into Return tube.

37. With suitable packer set installed between flanges to eliminate gap.

Note: Up to 3 x 6250024 - SPACER S/STEP / RETURN LG RAD may be installed between Side Step and Side Rail Brackets to obtain better fitment.

38. Ensure the top faces of the curved section and the side rail are parallel and tighten the fasteners.

Torque to Specification.

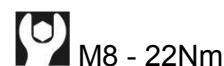

FRONT SIDE RAIL & SIDE STEP RETURN FITMENT TO VEHICLE

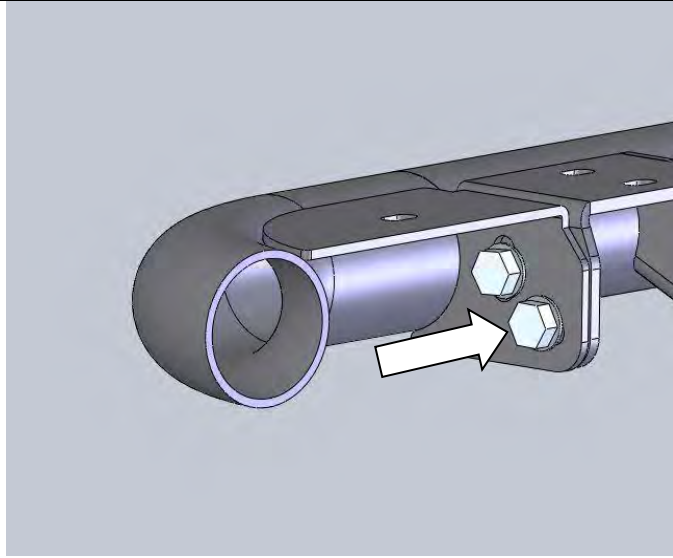

39. Using an electric drill with an Ø8mm drill bit and the pre-cut hole in the curved end section as a guide, drill through the rear section.

NOTE: IT MAY BE NECESSARY TO TEMPORARILY REMOVE THE MUD FLAPS TO GAIN ACCESS WITH THE DRILL.

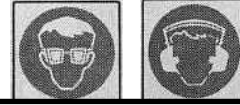

Warning: Drilling operations can result in flying metal debris, safety glasses should be worn.

40. Apply paint or a rust preventative to the bare metal.
41. Pin the curved end section to the rear section using an M8X20 Bolt, 2 x M8 Flat Washers and an M8 Nyloc Nut.

Torque to Specification. Repeat on other side.

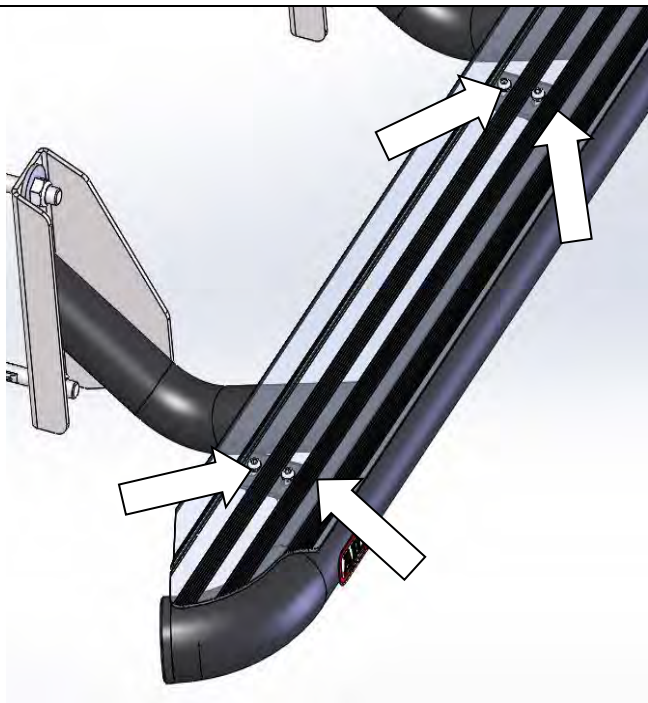
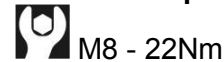

THE FOLLOWING STEPS APPLY TO BOTH SIDE RAIL AND FRONT SECTION FITMENT

42. Run a bead of silicone along the top of the rail where the Tread Plate will sit. (This will help prevent vibration).
43. Position the Tread Plate on the step, aligning the bolt holes with the corresponding holes in the side step. Starting at the front of the step, secure the checker top with S/Steel M6X16 Button Head Bolts, M6 Flat Washers and M6 Flange Nuts.

Note: Over tightening of bolts may result in damage to the Tread Plates.

Repeat step 36 - 45 on other side of vehicle.

Torque to Specification.

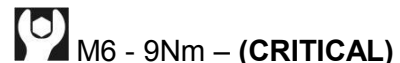

44. Apply the supplied ARB decals on the RH and LH rear of side steps as shown.

FITTED PRODUCT



MY 2009 ON SHOWN FITTED WITH 4421110 GUARD RAILS



MY 2009 ON SHOWN FITTED WITH 4421120 RETURN RAILS

FITTED PRODUCT



MY 2017 ON SHOWN FITTED WITH 4421130 GUARD RAILS